

JVC

SERVICE MANUAL

COMPACT COMPONENT SYSTEM

FS-Y1

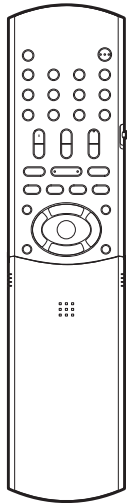

Area suffix

J ----- U.S.A.
C ----- Canada

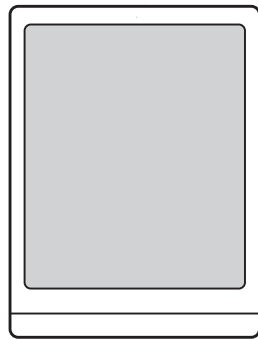

(SP-FSY1)

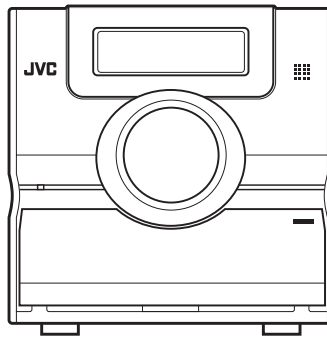

(CA-FSY1)

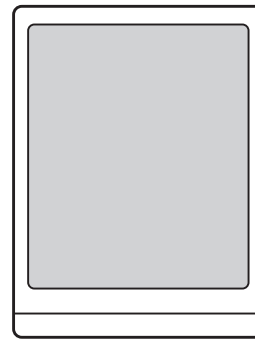

(SP-FSY1)



Lead free solder used in the board (material : Sn-Ag-Cu, melting point : 219 Centigrade)

TABLE OF CONTENTS

1	PRECAUTION	1-3
2	SPECIFIC SERVICE INSTRUCTIONS	1-5
3	DISASSEMBLY	1-6
4	ADJUSTMENT	1-23
5	TROUBLESHOOTING	1-33

SPECIFICATION

General	Power source	AC 120 V , 60 Hz
	Power consumption	25 W (in operation) 1.0 W (on standby)
	Weight	2.7 kg (6.0 lbs)
	External dimensions (W x H x D)	150 mm x 152 mm x 246 mm (5 15/16 in. x 6 in. x 9 11/16 in.)
DVD player	Playable discs	DVD VIDEO, DVD AUDIO, VCD, SVCD, CD, CD-R/RW (CD, VCD, MP3, WMA, JPEG format), DVD-R/-RW (video format)
Video output	Color system	NTSC
	Horizontal resolution	500 lines
	Composite x 1	1.0 V (p-p)/75 Ω , synchronization negative
	S-video x 1	Y output: 1.0 V (p-p)/75 Ω , synchronization negative C output: 0.286 V (p-p)/75 Ω
	Component x 1	Y output: 1.0 V (p-p)/75 Ω PB/PR output: 0.7 V (p-p)/75 Ω
Audio output	Analog sound output	Speakers x 2
	Output power	18 W per channel, min. RMS, at 4 Ω at 1 kHz with no more than 10% total harmonic distortion
	Fitting impedance	4 Ω to 16 Ω
	Headphones x 1	11 mW/32 Ω
	Fitting impedance	16 Ω to 1 k Ω
	Subwoofer x 1	500 mVrms/10 k Ω
	Digital sound output	
	Optical x 1	-21 dBm to -15 dBm
Audio input	Sound input	AUX x1: 400 mV/50 k Ω
Tuner	FM tuner	Receiving frequency: 87.5 MHz to 108.0 MHz Antenna: 75 Ω - Unbalanced type
	AM tuner	Receiving frequency: 530 kHz to 1 710 kHz Antenna: External antenna jack (loop antenna)
Speaker	Type	Full range
	Speaker	1-way bass-reflex type Magnetically shielded type 8cm (3 3/16 inches) cone x 1
	Frequency response	60 to 20 000 Hz
	Power handling capacity	20 W
	Impedance	4 Ω
	Sound pressure level	81 dB/W m
	Dimension (W x H x D)	120 mm x 150 mm x 188 mm (43/4 in. x 515/16 in. x 77/16 in.)
	Weight (1 unit)	1.5 kg (3.4 lbs)

Designs and Specifications are subject to change without notice.

SECTION 1 PRECAUTION

1.1 Safety Precautions

- (1) This design of this product contains special hardware and many circuits and components specially for safety purposes. For continued protection, no changes should be made to the original design unless authorized in writing by the manufacturer. Replacement parts must be identical to those used in the original circuits. Services should be performed by qualified personnel only.
- (2) Alterations of the design or circuitry of the product should not be made. Any design alterations of the product should not be made. Any design alterations or additions will void the manufacturer's warranty and will further relieve the manufacturer of responsibility for personal injury or property damage resulting therefrom.
- (3) Many electrical and mechanical parts in the products have special safety-related characteristics. These characteristics are often not evident from visual inspection nor can the protection afforded by them necessarily be obtained by using replacement components rated for higher voltage, wattage, etc. Replacement parts which have these special safety characteristics are identified in the Parts List of Service Manual. Electrical components having such features are identified by shading on the schematics and by (Δ) on the Parts List in the Service Manual. The use of a substitute replacement which does not have the same safety characteristics as the recommended replacement parts shown in the Parts List of Service Manual may create shock, fire, or other hazards.
- (4) The leads in the products are routed and dressed with ties, clamps, tubings, barriers and the like to be separated from live parts, high temperature parts, moving parts and/or sharp edges for the prevention of electric shock and fire hazard. When service is required, the original lead routing and dress should be observed, and it should be confirmed that they have been returned to normal, after reassembling.
- (5) Leakage shock hazard testing

After reassembling the product, always perform an isolation check on the exposed metal parts of the product (antenna terminals, knobs, metal cabinet, screw heads, headphone jack, control shafts, etc.) to be sure the product is safe to operate without danger of electrical shock. Do not use a line isolation transformer during this check.

- Plug the AC line cord directly into the AC outlet. Using a "Leakage Current Tester", measure the leakage current from each exposed metal part of the cabinet, particularly any exposed metal part having a return path to the chassis, to a known good earth ground. Any leakage current must not exceed 0.5mA AC (r.m.s.).
- Alternate check method
Plug the AC line cord directly into the AC outlet. Use an AC voltmeter having, 1,000 Ω per volt or more sensitivity in the following manner. Connect a 1,500 Ω 10W resistor paralleled by a 0.15 μ F AC-type capacitor between an exposed metal part and a known good earth ground. Measure the AC voltage across the resistor with the AC

voltmeter.

Move the resistor connection to each exposed metal part, particularly any exposed metal part having a return path to the chassis, and measure the AC voltage across the resistor. Now, reverse the plug in the AC outlet and repeat each measurement. Voltage measured any must not exceed 0.75 V AC (r.m.s.). This corresponds to 0.5 mA AC (r.m.s.).

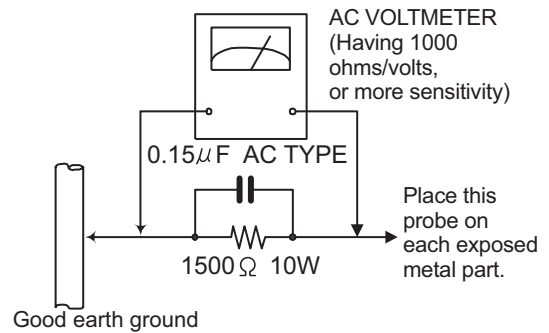

1.2 Warning

- (1) This equipment has been designed and manufactured to meet international safety standards.
- (2) It is the legal responsibility of the repairer to ensure that these safety standards are maintained.
- (3) Repairs must be made in accordance with the relevant safety standards.
- (4) It is essential that safety critical components are replaced by approved parts.
- (5) If mains voltage selector is provided, check setting for local voltage.

1.3 Caution

Burrs formed during molding may be left over on some parts of the chassis.

Therefore, pay attention to such burrs in the case of pre-forming repair of this system.

1.4 Critical parts for safety

In regard with component parts appearing on the silk-screen printed side (parts side) of the PWB diagrams, the parts that are printed over with black such as the resistor (■), diode (■) and ICP (●) or identified by the " Δ " mark nearby are critical for safety. When replacing them, be sure to use the parts of the same type and rating as specified by the manufacturer. (This regulation does not Except the J and C version)

1.5 Preventing static electricity

Electrostatic discharge (ESD), which occurs when static electricity stored in the body, fabric, etc. is discharged, can destroy the laser diode in the traverse unit (optical pickup). Take care to prevent this when performing repairs.

1.5.1 Grounding to prevent damage by static electricity

Static electricity in the work area can destroy the optical pickup (laser diode) in devices such as laser products. Be careful to use proper grounding in the area where repairs are being performed.

(1) Ground the workbench

Ground the workbench by laying conductive material (such as a conductive sheet) or an iron plate over it before placing the traverse unit (optical pickup) on it.

(2) Ground yourself

Use an anti-static wrist strap to release any static electricity built up in your body.

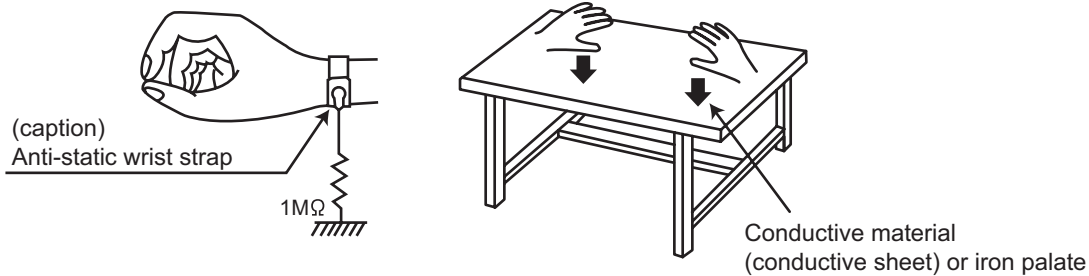

(3) Handling the optical pickup

- In order to maintain quality during transport and before installation, both sides of the laser diode on the replacement optical pickup are shorted. After replacement, return the shorted parts to their original condition. (Refer to the text.)
- Do not use a tester to check the condition of the laser diode in the optical pickup. The tester's internal power source can easily destroy the laser diode.

1.6 Handling the traverse unit (optical pickup)

- (1) Do not subject the traverse unit (optical pickup) to strong shocks, as it is a sensitive, complex unit.
- (2) Cut off the shorted part of the flexible cable using nippers, etc. after replacing the optical pickup. For specific details, refer to the replacement procedure in the text. Remove the anti-static pin when replacing the traverse unit. Be careful not to take too long a time when attaching it to the connector.
- (3) Handle the flexible cable carefully as it may break when subjected to strong force.
- (4) It is not possible to adjust the semi-fixed resistor that adjusts the laser power. Do not turn it.

1.7 Attention when traverse unit is decomposed

***Please refer to "Disassembly method" in the text for the pickup unit.**

- Apply solder to the short land sections before the flexible wire is disconnected from the connector on the servo board. (If the flexible wire is disconnected without applying solder, the pickup may be destroyed by static electricity.)
- In the assembly, be sure to remove solder from the short land sections after connecting the flexible wire.

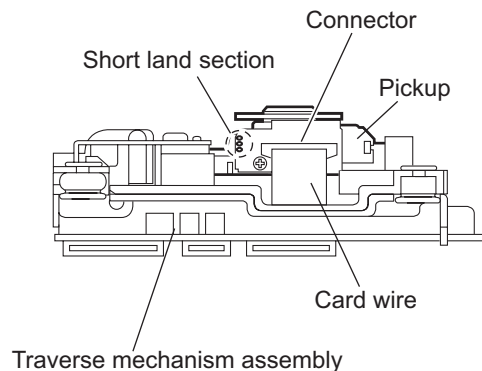

SECTION 2
SPECIFIC SERVICE INSTRUCTIONS

This service manual does not describe SPECIFIC SERVICE INSTRUCTIONS.

SECTION 3 DISASSEMBLY

3.1 Main body section

3.1.1 Removing the side panel L and side panel R (See Figs.1 to 4)

- (1) From the back side of the main body, remove the four screws **A** attaching the side panels L/R. (See Fig.1.)
- (2) From the bottom side of the main body, remove the four screws **B** attaching the side panels L/R. (See Fig.2.)
- (3) From the both sides of the main body, release the joint **a** in the direction of the arrow and remove the side panels L/R toward this side. (See Figs.3 and 4.)

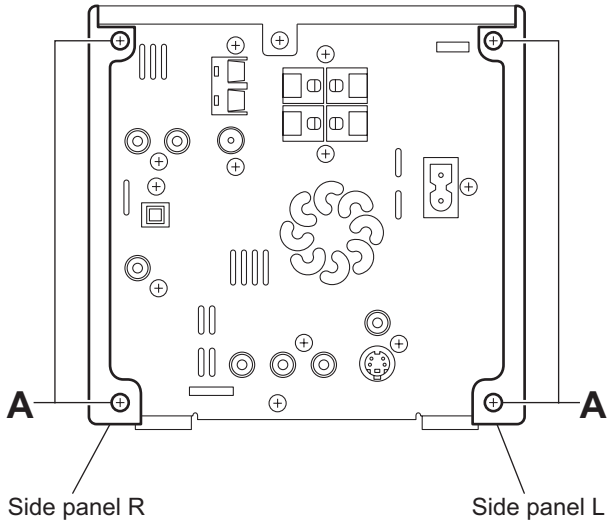

Fig.1

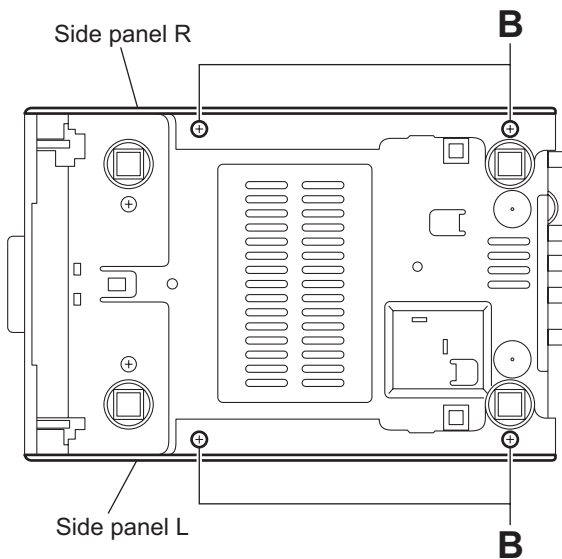

Fig.2

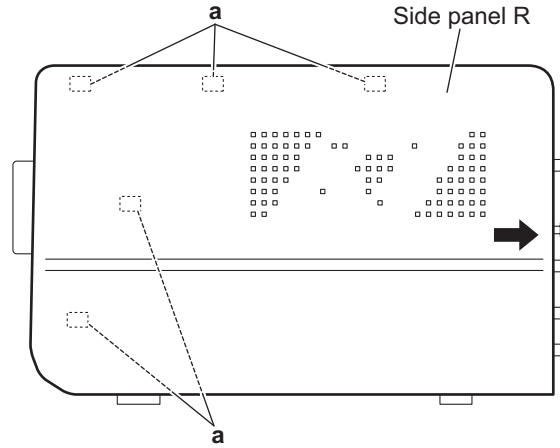

Fig.3

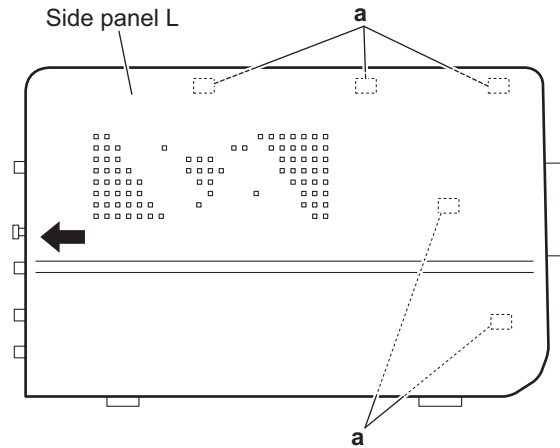

Fig.4

3.1.2 Removing the top panel assembly (See Figs.5 to 6)

- Remove the side panels L/R.
 - (1) From the front side of the main body, pull out the volume knob assembly in the direction of the arrow. (See Fig.5.)
 - (2) Remove the two screws **C** and remove the volume ornament. (See Fig.5.)
 - (3) From the both sides of the main body, remove the two screws **D**, two screws **E** and screw **F**. (See Figs.5 and 6)

Reference:

When attaching the screw **F**, attach the earth wire with it.
(See Fig.6.)

- (4) Remove the screw **G** attaching the top panel assembly.
(See Fig.6.)
- (5) Release the joints **b** and remove the joints **c** in the direction of the arrow. (See Figs.5 and 6.)
- (6) Disconnect the card wire from the connector **CN427** on the micom board while lifting the top panel assembly. (See Fig.5.)

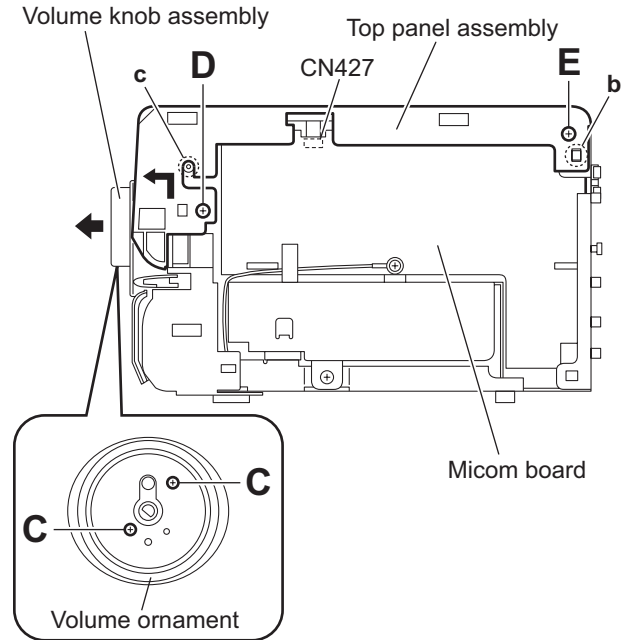

Fig.5

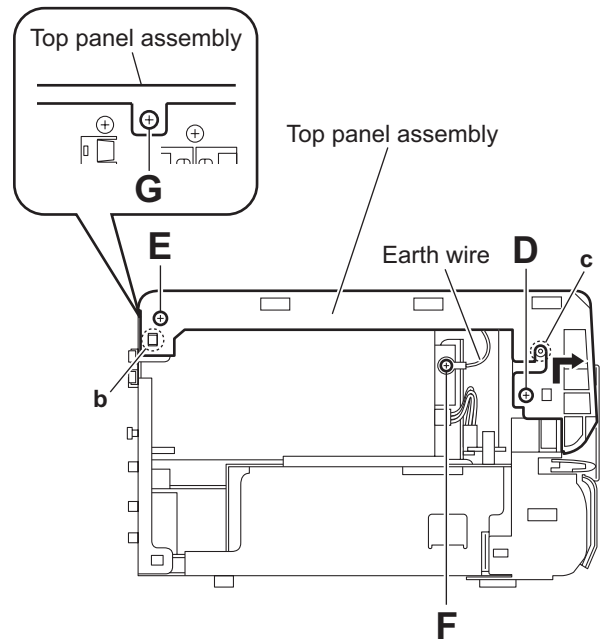

Fig.6

3.1.3 Removing the front panel assembly (See Figs.7 to 9)

- Remove the side panels L/R and top panel assembly.
 - (1) From the bottom side of the main body, remove the two screws **H** attaching the front panel assembly. (See Fig.7.)
 - (2) From the forward side of the micom board, disconnect the card wire from the connector **CN426**. (See Fig.8.)
 - (3) Disconnect the wire from the connector **CN501** on the micom board. (See Fig.8.)
 - (4) From the right side of the main body, remove the screw **J** and remove the earth wire. (See Fig.8.)

Reference:

- When attaching the screw **J**, attach the earth wire with it. (See Fig.8.)
 - After attaching the earth wire, fix it with the spacer as before. (See Fig.8.)
- (5) From the bottom and both sides of the main body, release the joints (**d**, **e**) of the front panel assembly and remove the front panel assembly in the direction of the arrow. (See Figs.7 to 9.)

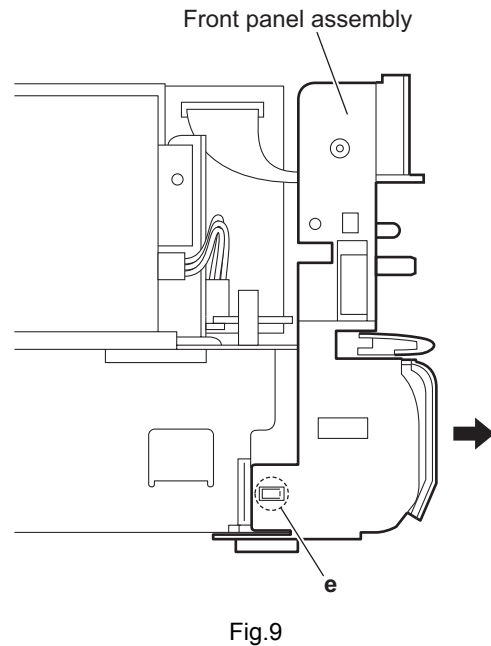
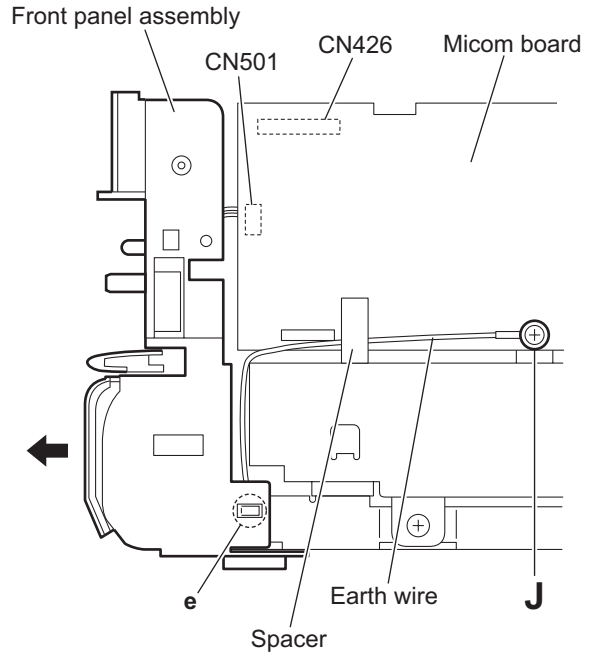
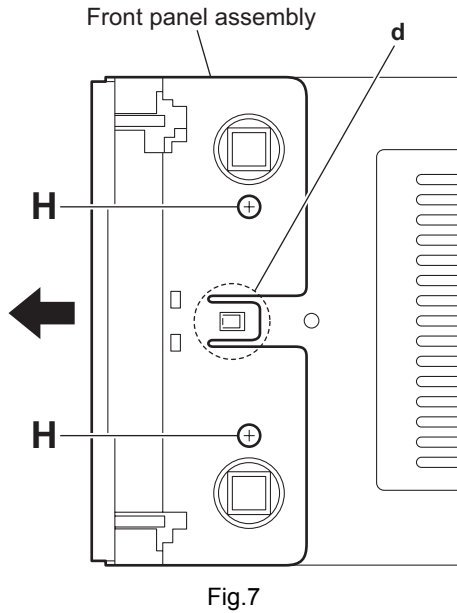

3.1.4 Removing the tuner (See Figs.10 and 11)

- Remove the side panels L/R and top panel assembly.
 - From the back side of the main body, remove the two screws **K** attaching the tuner to the rear panel. (See Fig.10.)
 - Disconnect the card wire from the connector **CN1** on the tuner. (See Fig.11.)

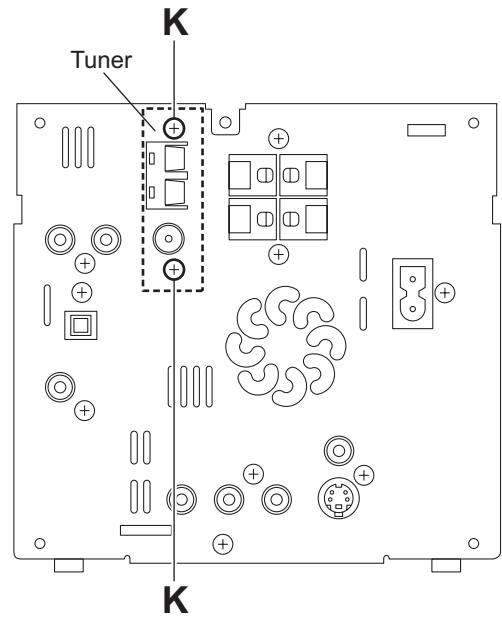

Fig.10

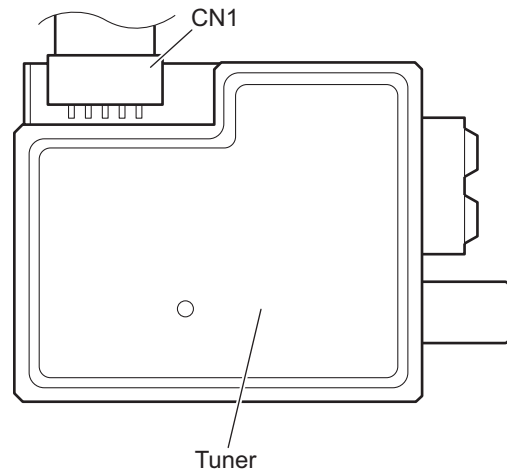

Fig.11

3.1.5 Removing the rear panel (See Fig.12)

- Remove the side panels L/R and top panel assembly.
 - From the back side of the main body, remove the ten screws **M** and screw **N** attaching the rear panel.
 - From the both sides of the main body, release the joints **f** and remove the rear panel.

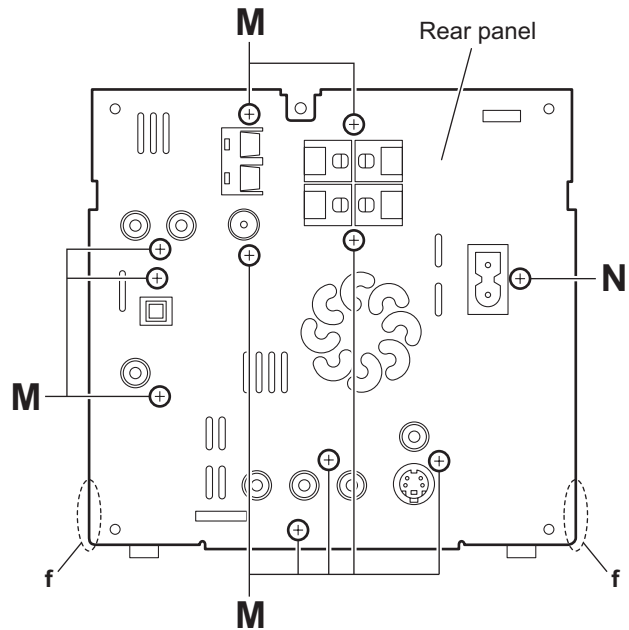

Fig.12

3.1.6 Removing the switching power supply (See Figs.13 and 14)

- Remove the side panels L/R, top panel assembly and rear panel.
 - (1) From the top side of the main body, disconnect the wires from the connector [CN200](#) on the regulator board. (See Fig.13.)
 - (2) Take out the switching power supply in the direction of the arrow. (See Fig.14.)

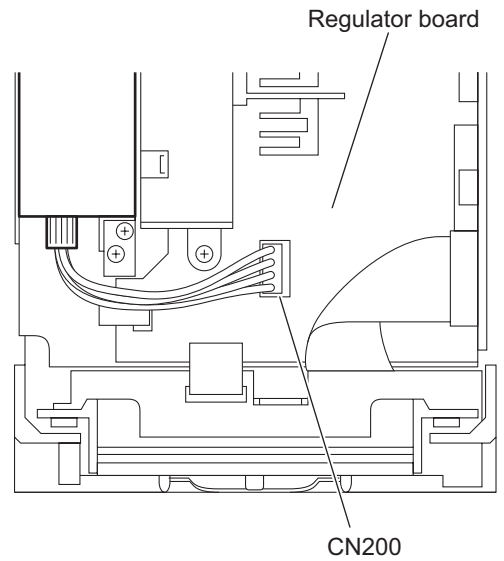

Fig.13

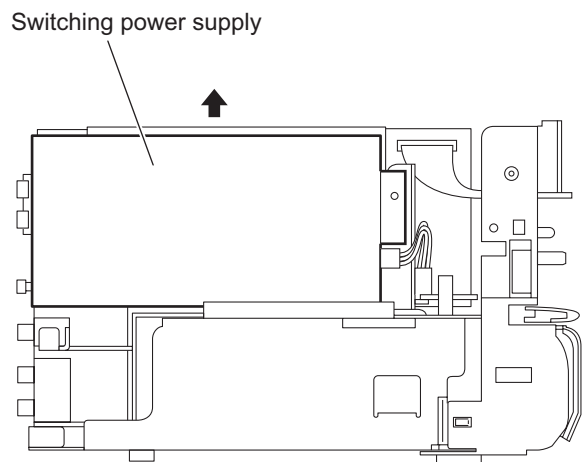

Fig.14

3.1.7 Removing the digital amplifier board assembly (See Figs.15 and 16)

- Remove the side panels L/R, top panel assembly, rear panel and switching power supply.
 - From the top side of the main body, remove the screw **P** attaching the digital amplifier board assembly. (See Fig.15.)
 - From the left side of the main body, disconnect the connectors (**CN310**, **CN311**, **CN312**) on the digital amplifier board assembly from the regulator board. (See Fig.16.)
 - Release the joint **g** of the shield case B in the direction of the arrow and take out the digital amplifier board assembly from the main body. (See Fig.16.)

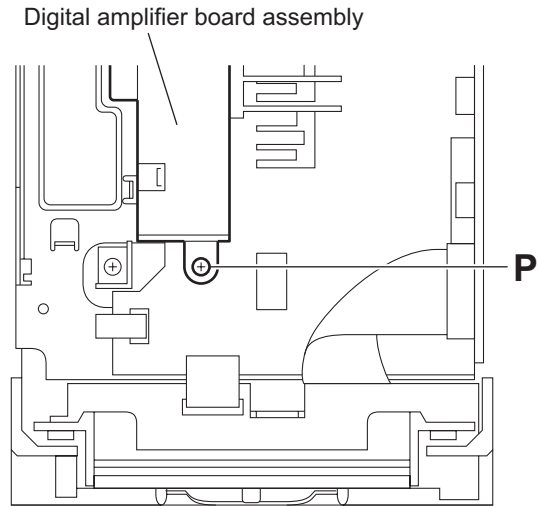

Fig.15

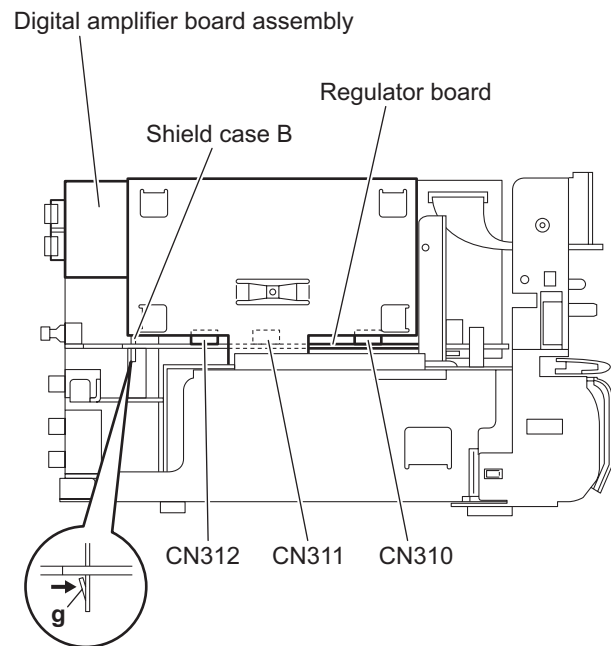

Fig.16

3.1.8 Removing the digital amplifier board (See Figs.17 to 22)

- Remove the side panels L/R, top panel assembly, rear panel, switching power supply and digital amplifier board assembly.
 - From the forward side of the digital amplifier board assembly, remove the screw **Q**. (See Fig.17.)
 - From the top and bottom sides of the digital amplifier board assembly, remove the three screws **R**. (See Figs.18 and 19.)
 - Release the joints (**h, j, k, m**) and remove the shield case B with the heat sink in the direction of the arrow. (See Figs.18 to 21.)
 - From the forward side of the digital amplifier board, remove the screw **R** attaching the heat sink. (See Fig.22.)
 - Remove the solders from the soldered sections (**n, p**) and bend the sections (**q, r**) of the shield case A in the direction of the arrow. (See Fig.22.)
 - Take out the digital amplifier board from the shield case A.

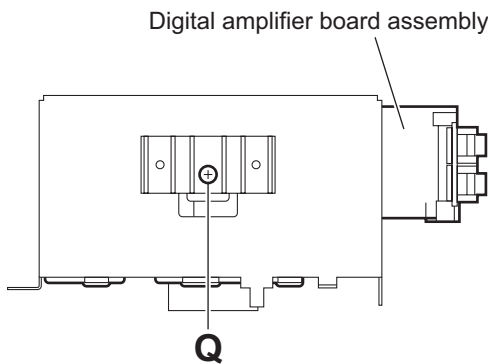

Fig.17

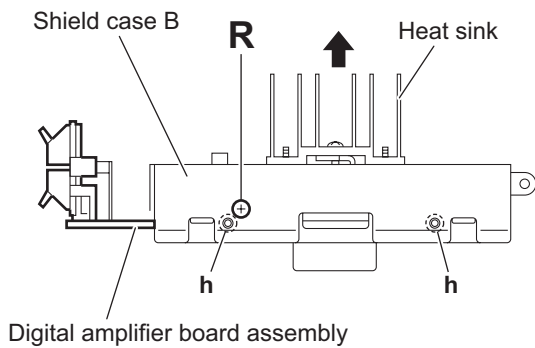

Fig.18

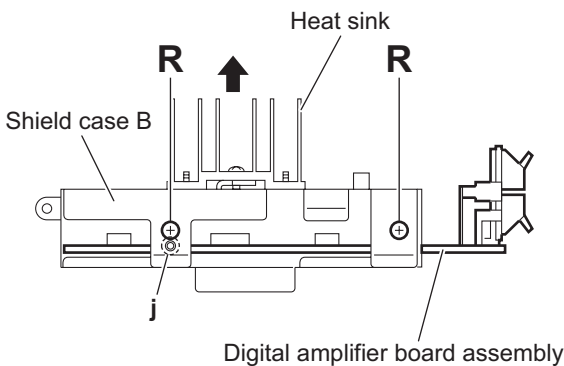

Fig.19

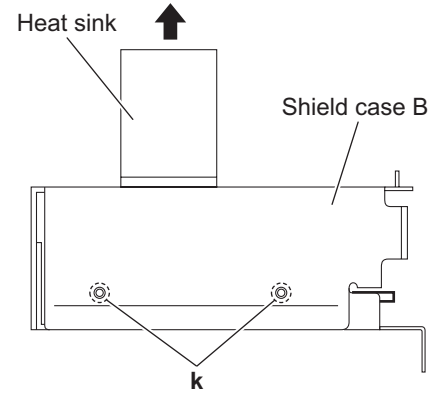

Fig.20

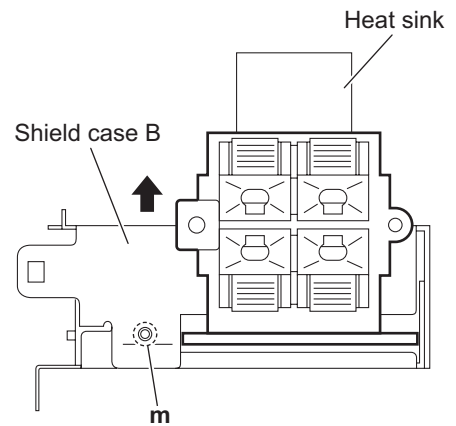

Fig.21

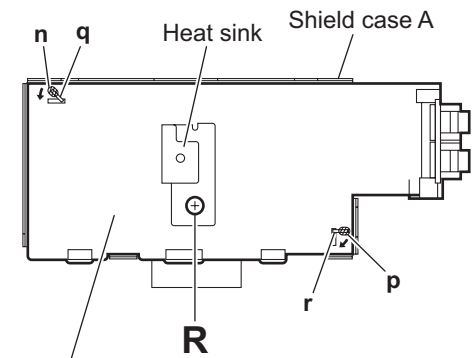

Fig.22

3.1.9 Removing the micom board (See Fig.23)

- Remove the side panels L/R, top panel assembly and rear panel.

(1) From the right side of the main body, remove the screw **S** attaching the micom board.

Reference:

- When attaching the screw **S**, attach the earth wire with it.
- After attaching the earth wire, fix it with the spacer as before.

(2) Disconnect the card wire from the connector **CN421** on the forward side of the micom board.

Reference:

Remove the tuner as required. (See Figs.10 and 11.)

(3) Disconnect the card wire from the connector **CN426** on the forward side of the micom board.

(4) Disconnect the wire from the connector **CN501** on the forward side of the micom board.

(5) Disconnect the connectors (**CN423**, **CN424**, **CN425**) on the micom board from the regulator board toward this side to remove the micom board.

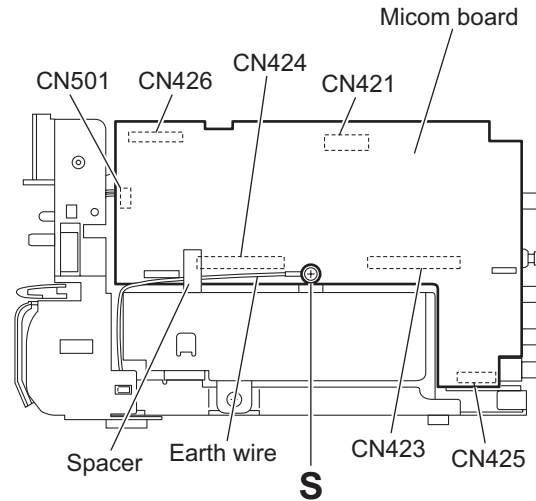

Fig.23

3.1.10 Removing the regulator board (See Fig.24)

- Remove the side panels L/R, top panel assembly, tuner, rear panel, switching power supply, digital amplifier board assembly and micom board.

(1) From the top side of the main body, disconnect the card wires from the connectors (**CN208**, **CN210**) on the regulator board.

Reference:

When connecting the card wire to the connector **CN208**, pass it through the hole **s** of the regulator board as before.

(2) Remove the three screws **T** and take out the regulator board.

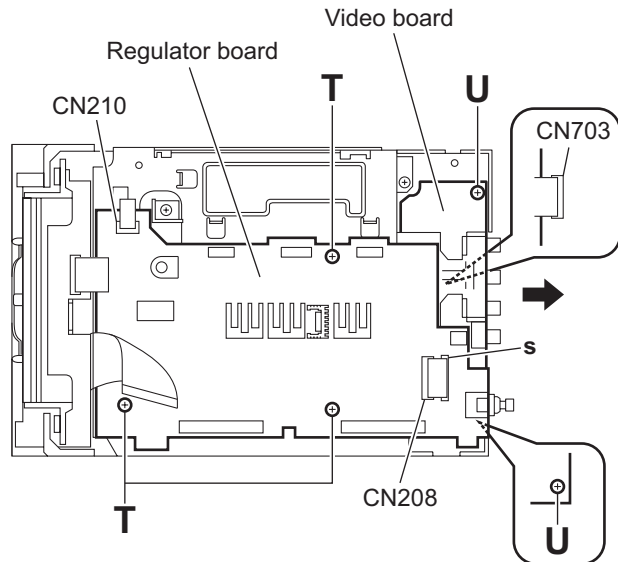

Fig.24

3.1.11 Removing the video board (See Fig.24)

- Remove the side panels L/R, top panel assembly, tuner, rear panel, switching power supply, digital amplifier board assembly and micom board.

Reference:

Remove the regulator board as required.

(1) From the top side of the main body, remove the two screws **U** and take out the video board in the direction of the arrow.

(2) Disconnect the card wire from the connector **CN703** on the video board.

3.1.12 Removing the DVD mechanism assembly (See Figs.25 to 28)

- Remove the side panels L/R, top panel assembly, tuner, rear panel, switching power supply, digital amplifier board assembly, micom board and regulator board.

- From the right side of the main body, remove the screw **V** attaching the metal chassis. (See Fig.25.)
- From the top side of the main body, remove the two screws **W** and take out the metal chassis. (See Fig.26.)

Reference:

When attaching the metal chassis, pass the card wire through the hole **t** on the metal chassis as before.

- Disconnect the card wire from the connector **CN703** on the video board. (See Fig.27.)
- Remove the screw **X** and take out the DVD mechanism assembly from the bottom chassis. (See Fig.27.)

Reference:

When the resolution of DVD mechanism assembly is done sequentially, remove a CD fitting in the direction of the arrow. (See Fig.28.)

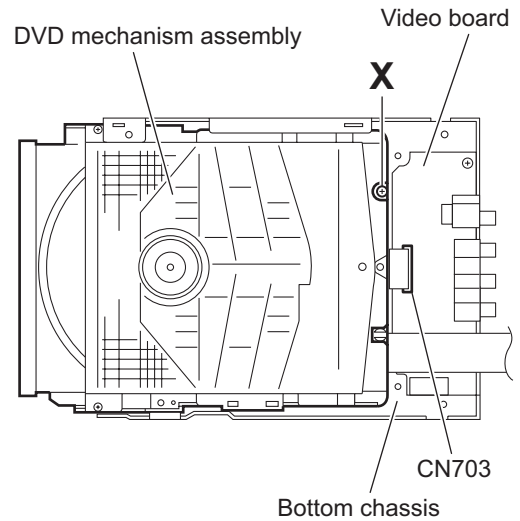

Fig.27

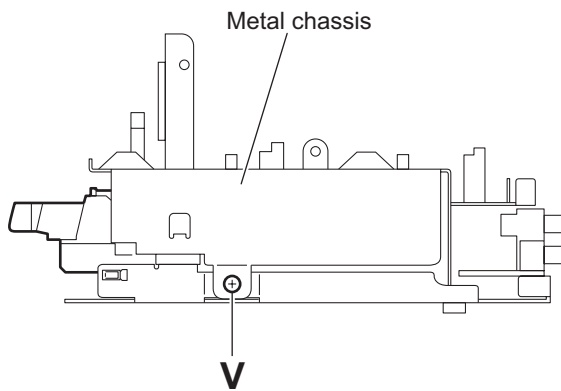

Fig.25

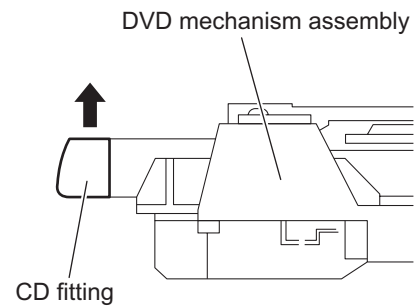

Fig.28

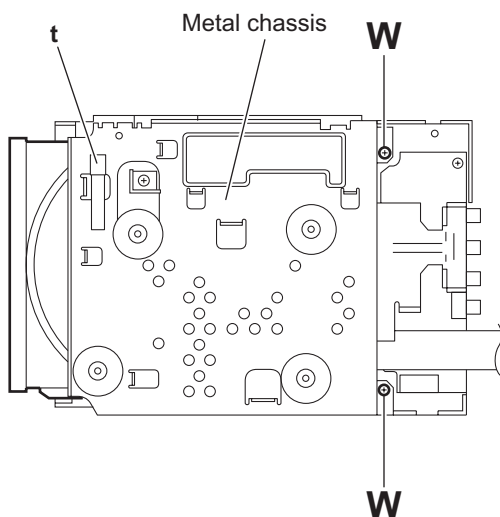

Fig.26

3.1.13 Removing the switch board (See Fig.29)

- Remove the side panels L/R and top panel assembly.
From the inside of the top panel assembly, remove the three screws **Y** and take out the switch board.

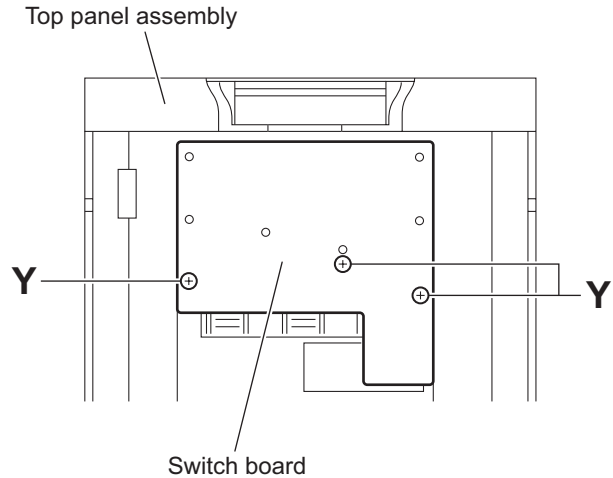

Fig.29

3.1.14 Removing the front board (See Fig.30)

- Remove the side panels L/R, top panel and front panel assemblies.
(1) From the inside of the front panel assembly, disconnect the card wire from the connector [CN605](#) on the front board.
(2) Remove the five screws **Z** and take out the front board.

3.1.15 Removing the FL board (See Fig.30)

- Remove the side panels L/R, top panel assembly, front panel assembly and front board.
Remove the two screws **Z** and take out the FL board.

3.1.16 Removing the headphone board (See Fig.30)

- Remove the side panels L/R, top panel and front panel assemblies.
(1) Remove the two screws **Z** and take out the support board.
(2) Take out the headphone board.

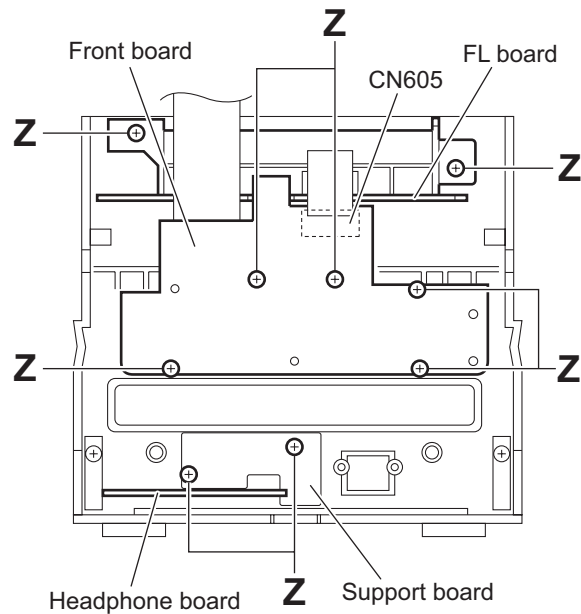

Fig.30

3.2 DVD mechanism section

- Remove the DVD mechanism assembly from the main body.
(See "3.1.6 Removing the DVD mechanism assembly".)

3.2.1 Removing the clamber base (See Fig.1)

- (1) From the top side of the DVD mechanism assembly, remove the two screws **A** attaching the clamber base.
- (2) Lift the clamber base in an upward direction to remove it from the projections **a** of the DVD mechanism assembly.
- (3) Slide the clamber base in the direction of the arrow and remove it from the joints **b**.

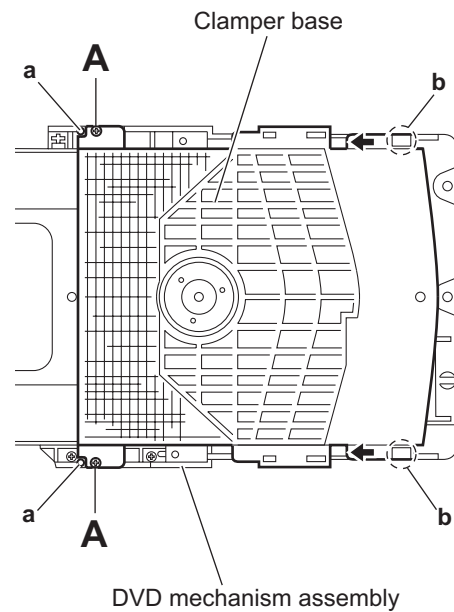

Fig.1

3.2.2 Removing the tray assembly (See Fig.2)

- (1) From the top side of the DVD mechanism assembly, remove the two screws **B** attaching the shaft guide of the tray assembly.
- (2) Remove the tray assembly from the projections **c** of the DVD mechanism assembly and take out the tray assembly.

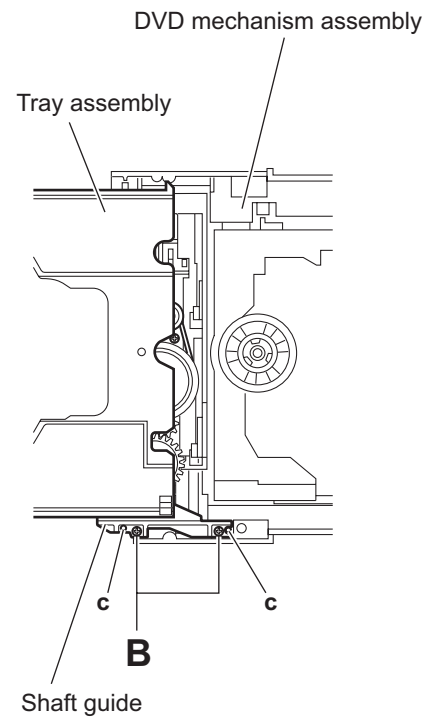

Fig.2

3.2.3 Removing the traverse mechanism assembly (See Figs.3)

- (1) From the bottom side of the DVD mechanism assembly, remove the four screws **C** attaching the traverse mechanism assembly.
- (2) Take out the traverse mechanism assembly with the DVD module board.

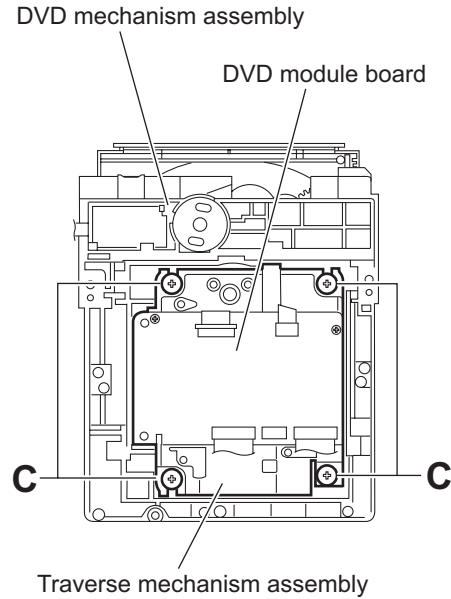

Fig.3

3.2.4 Removing the DVD module board (See Figs.4 and 5)

- Remove the traverse mechanism assembly.
 - (1) From the side of the traverse mechanism assembly, solder the short land sections **d** on the pickup. (See Fig.4.)
 - (2) From the bottom side of the traverse mechanism assembly, release the lock of the connector **CN101** on the DVD module board in the direction of the arrow 1 and disconnect the card wire. (See Fig.5.)

Caution:

- Solder the short land sections **d** on the pickup before disconnecting the card wire from the connector **CN101** on the DVD module board. If the card wire is disconnected without attaching solder, the pickup may be destroyed by static electricity. (See Figs.4 and 5.)
- When attaching the DVD module board, be sure to remove solders from the short land sections **d** after connecting the card wire to the connector **CN101** on the DVD module board. (See Figs.4 and 5.)

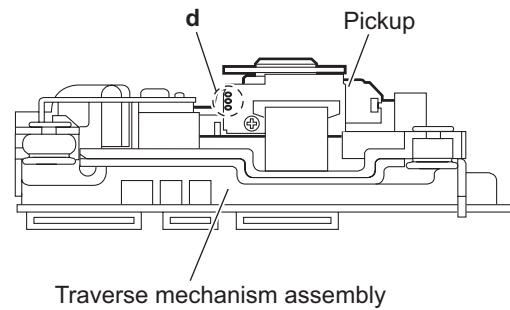

Fig.4

- (3) Disconnect the card wire from the connector **CN201** on the DVD module board. (See Fig.5.)
- (4) Remove the two screws **D** attaching the DVD module board. (See Fig.5.)
- (5) Remove the DVD module board from the projection **e** in an upward direction and remove the engagement section **g** in the direction 3 while removing the engagement section **f** in the direction of the arrow 2. (See Fig.5.)

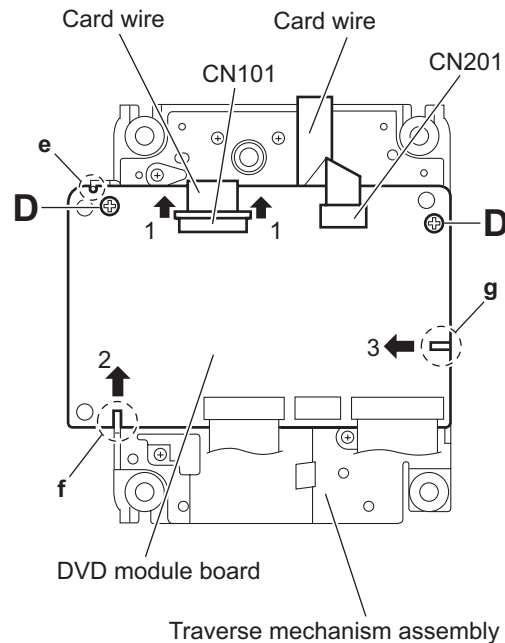

Fig.5

3.2.5 Removing the pickup (See Figs.4,6 to 8)

- Remove the traverse mechanism assembly.

- From the side of the traverse mechanism assembly, solder the short land sections **d** on the pickup. (See Fig.4.)
- Release the lock of the connector on the pickup in the direction of the arrow and disconnect the card wire. (See Fig.6.)

Caution:

- Solder the short land sections **d** on the pickup before disconnecting the card wire from the connector on the pickup. If the card wire is disconnected without attaching solder, the pickup may be destroyed by static electricity. (See Figs.4 and 6.)
- When attaching the pickup, be sure to remove solders from the short land sections **d** after connecting the card wire to the connector on the pickup. (See Figs.4 and 6.)

- Remove the screw **E** attaching the plate and thrust spring. (See Fig.6.)
- Remove the engagement section **h** attaching the plate to the feed holder and remove the plate. (See Fig.6.)
- Remove the engagement sections (**i, j**), remove the thrust spring. (See Fig.6.)
- Remove the shaft of the pickup from the section **k** on the traverse mechanism assembly and remove the shaft from the section **m** while moving it in the direction of the arrow. (See Fig.7.)
- Remove the pickup from the section **n** of the traverse mechanism assembly and take out the pickup with the shaft. (See fig.7.)
- From the bottom side of the pickup, remove the two screws **F** attaching the SW actuator and lead spring. (See Fig.8.)
- Pull the shaft out of the pickup. (See Fig.8.)

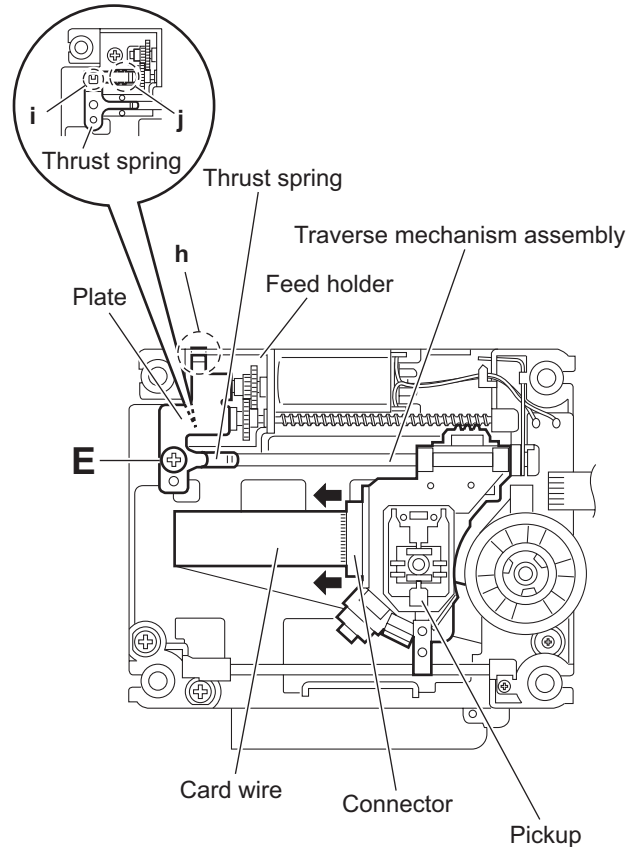

Fig.6

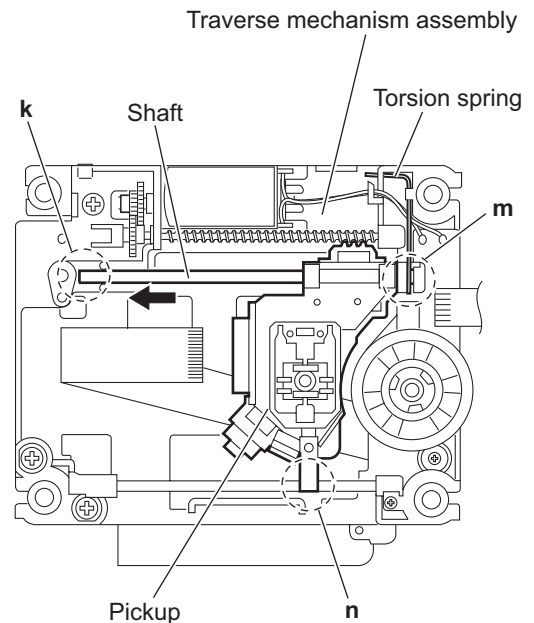

Fig.7

3.2.6 Attaching the pickup (See Figs.4,6 to 9)

- See "3.2.5 Removing the pickup".

- (1) Attach the shaft, SW actuator and lead spring to the pickup.
(See Fig.8.)
- (2) Align the pickup to the section **n** of the traverse mechanism assembly first and set the both ends of the shaft of the pickup in the sections (**k**, **m**) of the traverse mechanism assembly. (See Fig.7.)

Note:

When attaching the shaft to the section **m**, attach it under the torsion spring. (See Fig.7.)

- (3) Attach the plate and thrust spring. (See Fig.6.)
- (4) Remove solders from the short land sections **d** after connecting the card wire to the connector on the pickup. (See Figs.4 and 6.)
- (5) Turn the feed gear M in the direction of the arrow 1 to move the pickup in the direction of the arrow 2. (See Fig.9.)

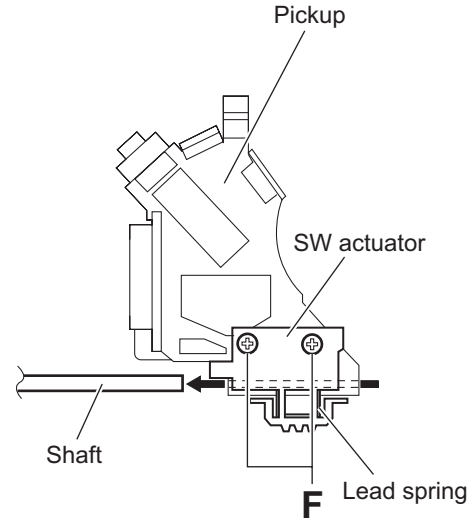

Fig.8

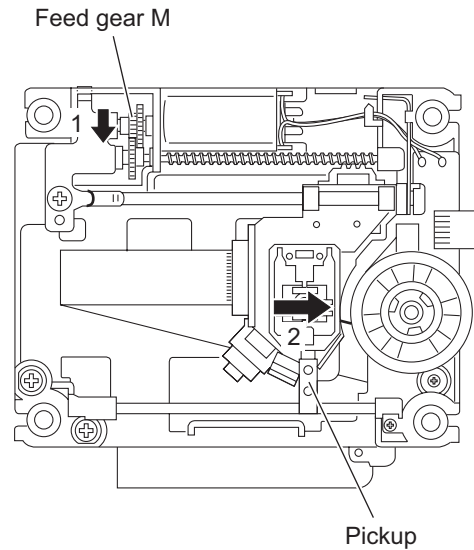

Fig.9

3.2.7 Removing the feed motor (See Figs.10 to 12)

- Remove the traverse mechanism assembly.
 - From the top side of the traverse mechanism assembly, remove the screw **G** attaching the plate and thrust spring. (See Fig.10.)
 - Remove the engagement section **p** attaching the plate to the feed holder and remove the plate. (See Fig.10.)
 - Remove the engagement sections (**q, r**), remove the thrust spring. (See Fig.10.)
 - Remove the wires from the soldered section **s** on the spindle motor board. (See Fig.11.)

Reference:

When attaching the feed motor, pass the wire through the section **t** on the spindle base. (See Fig.11.)

- Remove the feed holder, feed motor, lead screw, feed gear E and feed gear M at the same time after removing the three screws **H** attaching the feed holder. (See Fig.11.)
- From the side of the feed holder, remove the two screws **J** attaching the feed motor. (See Fig.12.)

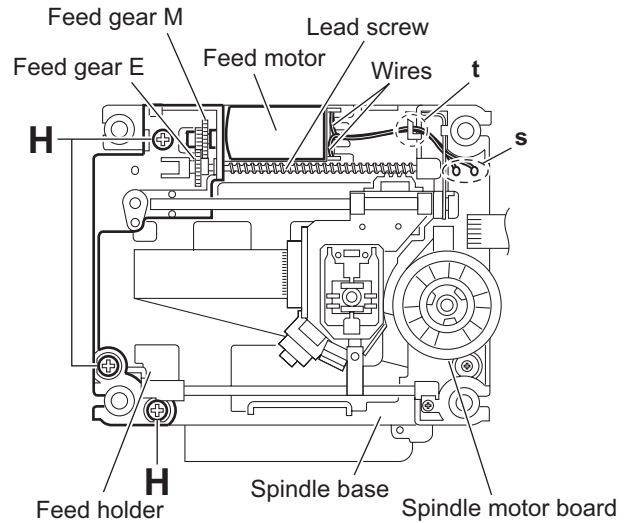

Fig.11

3.2.8 Removing the spindle motor board (See Figs.11 and 13)

- Remove the traverse mechanism assembly and DVD module board.
 - From the top side of the traverse mechanism assembly, remove the wires from the soldered section **s** on the spindle motor board. (See Fig.11.)
 - From the bottom side of the traverse mechanism assembly, remove the three screws **K** attaching the spindle motor board. (See Fig.13.)

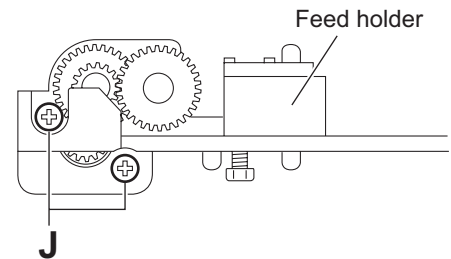

Fig.12

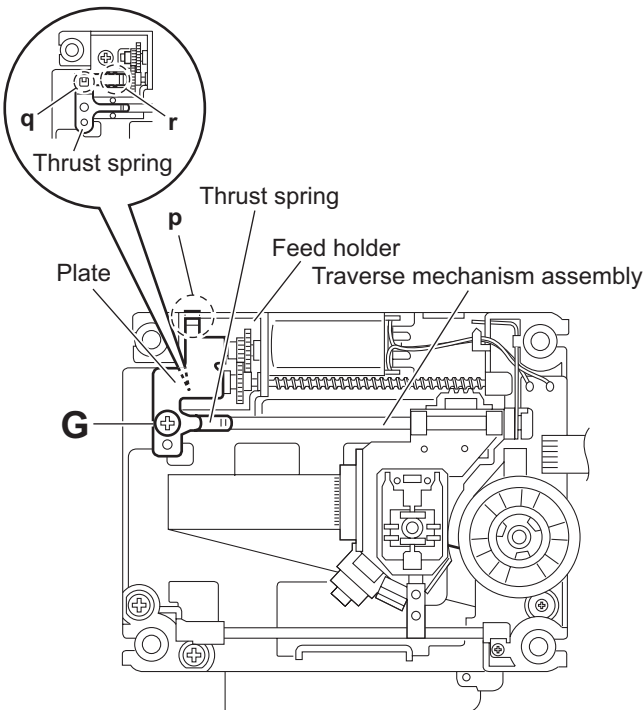

Fig.10

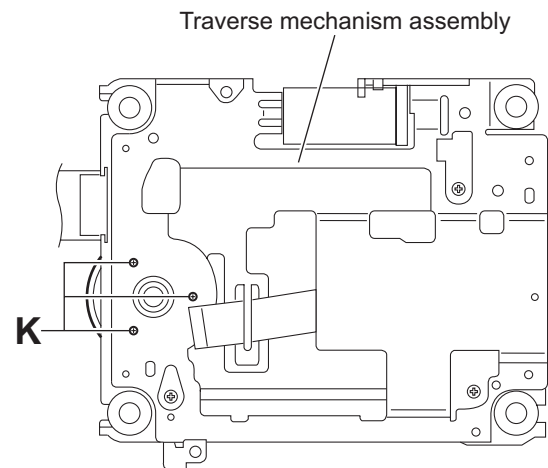

Fig.13

3.2.9 Removing the switch board (See Fig.14.)

- (1) From the bottom side of the DVD mechanism assembly, remove the screw **L** attaching the switch board.
- (2) Disconnect the card wire from the connector **CN1** on the switch board.
- (3) Remove the wires from the soldered section **u** on the switch board.
- (4) Lift the switch board while pressing the claw **v** of the DVD mechanism assembly in the direction of the arrow and remove it from the section **w**.

Reference:

Put the wires on the section **x** after attaching the switch board to the DVD mechanism assembly.

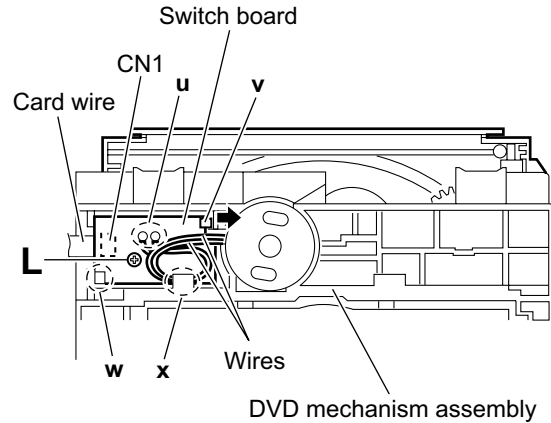

Fig.14

3.2.10 Removing the motor (See Figs.14 and 15)

- Remove the clamber base and tray assembly.

- (1) From the bottom side of the DVD mechanism assembly, remove the wires from the soldered section **u** on the switch board. (See Fig.14.)
- (2) From the top side of the DVD mechanism assembly, remove the belt from the motor pulley. (See Fig.15.)

Note:

Take care not to attach grease on the belt.

- (3) Remove the two screws **M** attaching the motor to the DVD mechanism assembly and take out the motor from the bottom side of the DVD mechanism assembly. (See Fig.15.)

Reference:

Put the wires on the section **x** after attaching the motor to the DVD mechanism assembly. (See Fig.14.)

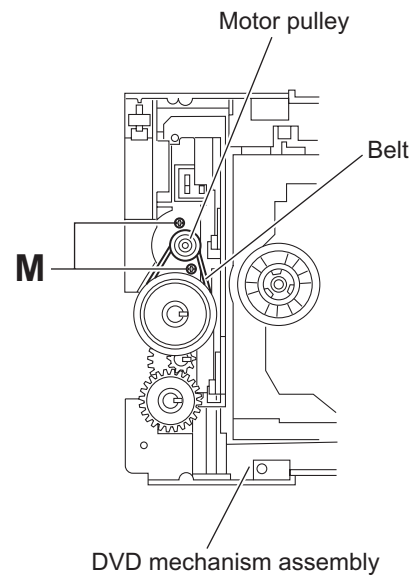

Fig.15

SECTION 4 ADJUSTMENT

4.1 Service mode

4.1.1 Confirming contents

- (1) Tuner AM switch to 9kHz-step
- (2) Tuner AM switch to 10kHz-step
- (3) Cold start
- (4) Tray lock
- (5) DVD test mode
- (6) DVD initialize

4.1.2 Confirming methods

1. Tuner AM switch to 9kHz-step
AM frequency change to 9kHz at U & A-version.

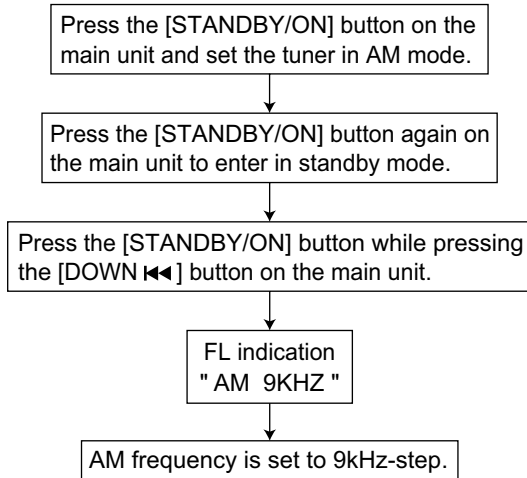

2. Tuner AM switch to 10kHz-step
AM frequency change to 10kHz at U & A-version.

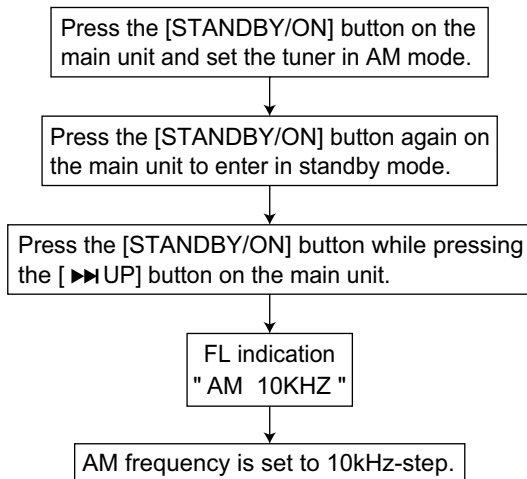

3. Cold start
Cold start processing.

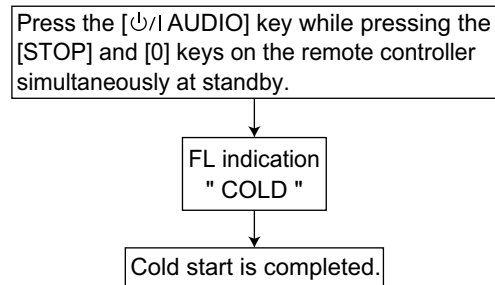

4. Tray lock
Loader-mecha is locked.
EJECT processing isn't done by pushing EJECT key at tray lock on state.
Then display to LOCKED / UNLOCKED.
EJECT is pushed, pushing STOP again, tray lock is off.
Back up to tray locked ON/OFF.

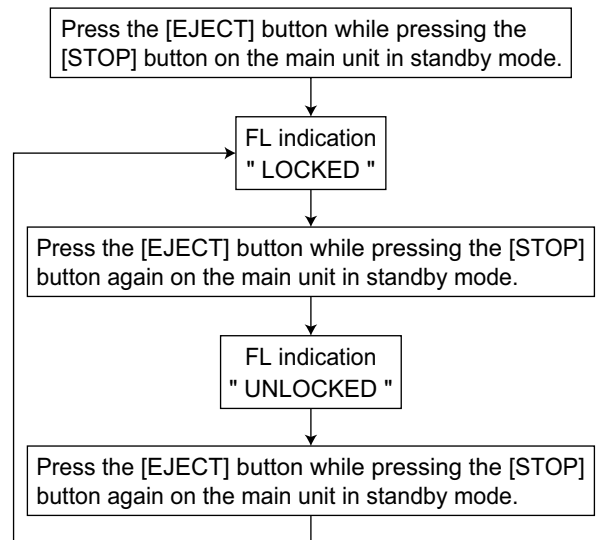

5. DVD test mode

In to the DVD test mode.

Test mode contents is refer to module specification.
DVD test mode is canceled by POWER OFF and except source DVD.

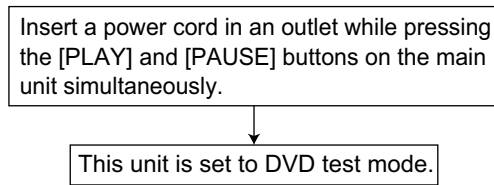

* The details refer to "4.1.3 DVD test mode".

6. DVD initialize

DVD module initialized.

LCD segment is light on at initialize command.

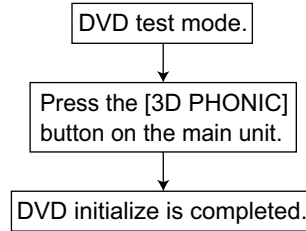

4.1.3 DVD test mode

1. To enter DVD TEST mode,

- (1) AC POWER ON while holding PLAY+PAUSE keys.
- (2) DVD Mecha will start in TEST MODE, FL will display:

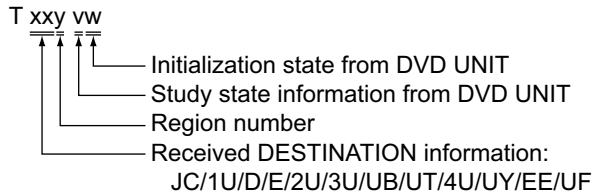

2. To exit DVD TEST mode,

- During TEST MODE (except for Device Key write & DVD Region Re-write), press POWER KEY.
- To exit TEST mode for Device Key Write & DVD Region Re-write, first AC OFF, then AC ON again to return to normal state.

3. EEPROM INITIALIZATION

3.1 NORMAL INITIALIZE

- (1) During DVD TEST MODE, press STOP key on remote control to start NORMAL EEPROM INITIALIZATION.
- (2) FL will display:

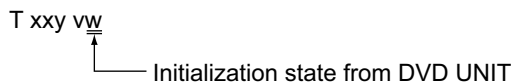

3.2 FULL INITIALIZE

- (1) During DVD TEST MODE, press >>| key on set 2 seconds control to start FULL EEPROM INITIALIZATION.
- (2) FL will display:

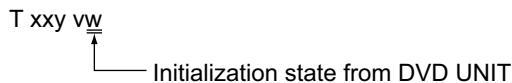

4. DEVICE KEY CHECKSUM DISPLAY

- (1) During DESTINATION INFO display screen (1), press MENU key to enter DEVICE KEY CHECKSUM display.
- (2) FL will display:

DKxxxx (Example) DK470B

5. DVD check mode

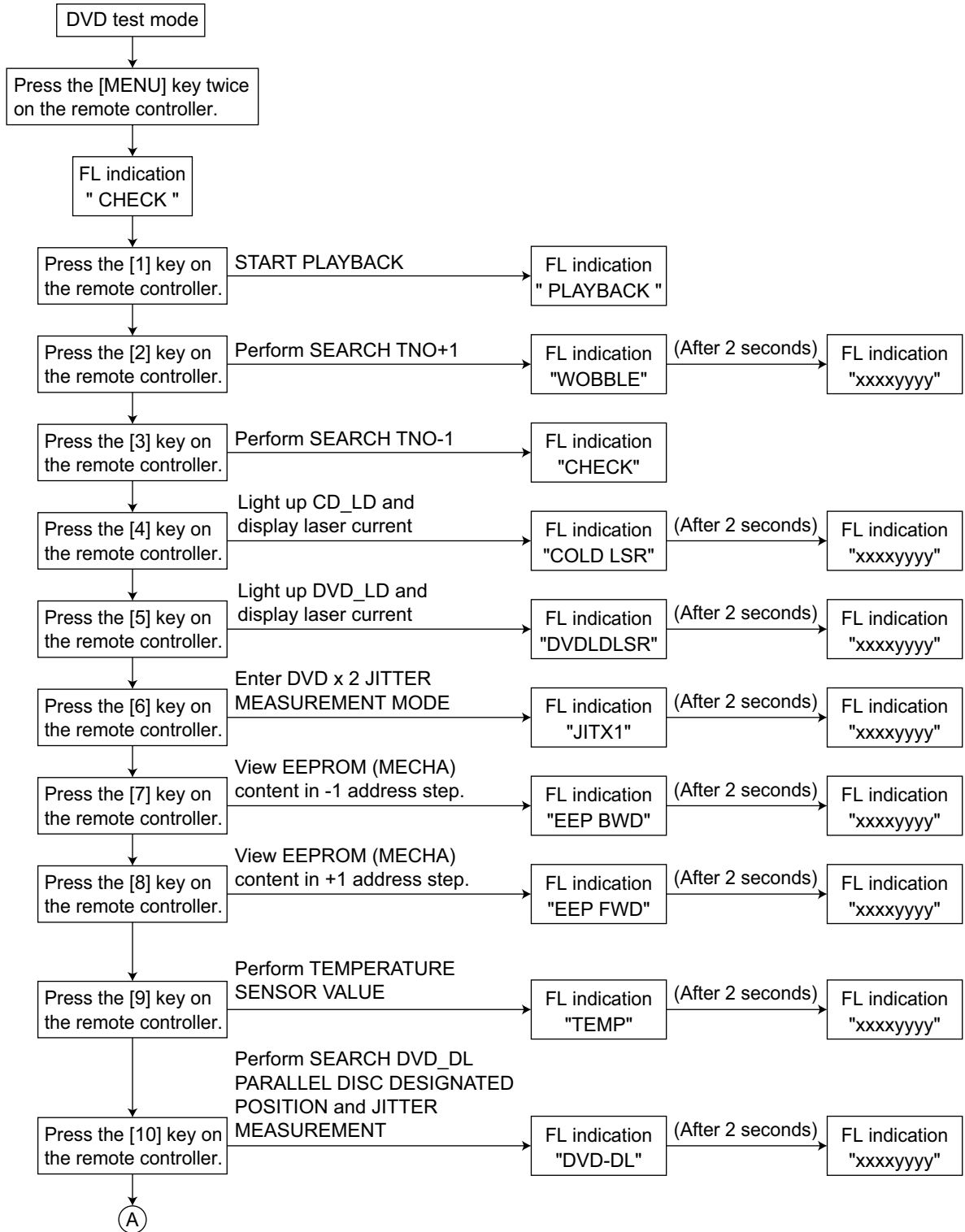

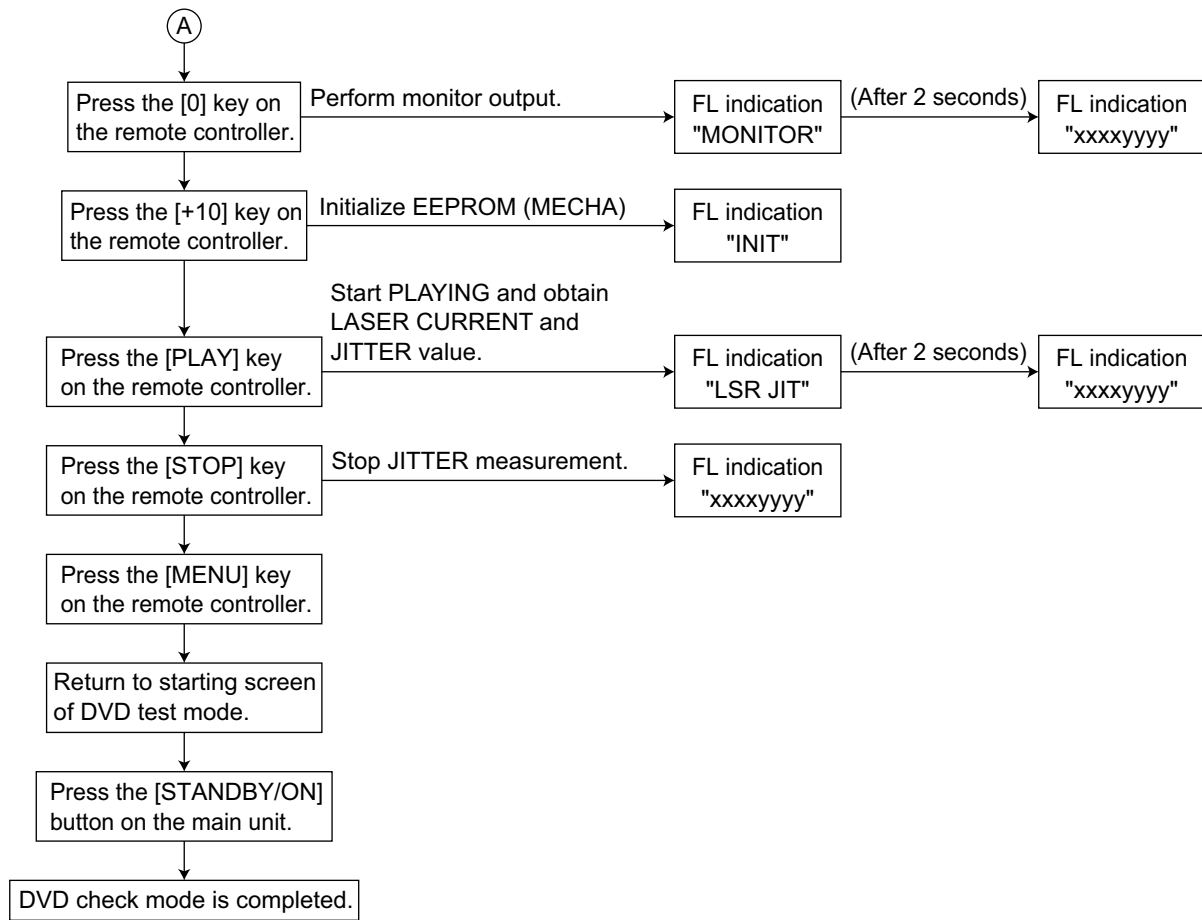

4.2 Indicating check for FL display

4.2.1 FL display (DVD function)

No.	Function	FL display										Note			
1	DVD					D	V	D							
2	OPEN DVD Other source					O	P	E	N					Under tray OPEN operation, and OPEN state. The last source is displayed.	
3	CLOSE DVD Other source					C	L	O	S	E				Under tray CLOSE operation. The last source is displayed.	
4	NO DISC DVD Other source					N	O	D	I	S	C			At the time of DISC-less decision. The last source is displayed.	
5	TOC READING					R	E	A	D	I	N	G			
6	POWER OFF					S	E	E	Y	O	U			Under POWER OFF processing. Other keys are not received while carrying out this processing.	
7	ERROR DISC REGION CODE ERROR	R	E	G	I	O	N			0	:	0	0	When DISC classification is 0x00 or 0x0C.	
	TRAY LOCK					L	O	C	K	E	D			At the time of TRAY LOCK	
	TRAY UNLOCK					U	N	L	O	C	K	E	D	At the time of TRAY LOCK release	
8	DVD AUDIO STOP					D	V	D		A	U	D	I	O	
		G	3							S	T	O	P		
		D	V	D	A					G	3		T	1	
	PLAY (TOP MENU/MENU)	D	V	D	A					M	E	N	U		
		D	V	D	A					M	E	N	U		
	PLAY	T	0	1		1	:	2	3	:	4	5			
		D	V	D	A			G	1		T	0	1		
	SEARCH	T	0	1		-	:	-	-	:	-	-			
		D	V	D	A			G	1		T	1	-		
	+10 KEY INPUT	T	1	-		1	:	2	3	:	4	5			
		D	V	D	A			G	1		T	1	-		
	GROUP +10 KEY INPUT	G	1	-		1	:	2	3	:	4	5			
		D	V	D	A			-		T		1			

No.	Function	FL display										Note
	REPEAT GROUP	display of Current condition										
	REPEAT TRACK	display of Current condition										
	PROGRAM (NO ENTRY)		P	R	O	G	R	A	M			
	PROGRAM (STOP)	P	2		G	2	T	1	5			
	PROGRAM (PLAY)	T	1	5	0	:	0	1	:	2	3	
	RANDOM (STOP)		R	A	N	D	O	M				
	RANDOM (SEARCH)	T	x	x	-	:	-	-	:	-	-	
	RANDOM (PLAY/PAUSE)	T		1	1	:	2	3	:	4	5	
	RESUME		R	E	S	U	M	E				
	DOWNMIX PROHIBITED		L	R	O	N	L	Y				
			M	U	L	T	I	C	H			
	WATER MARK		N	O	A	U	D	I	O			
9	DVD VIDEO											
	STOP	T	1	5		S	T	O	P			
		D	V	D		T	1	5	C	-	-	UNDER FL DISPLAY MODE
	PLAY (TITLE/MENU)	D	V	D		M	E	N	U			
		D	V	D		M	E	N	U			UNDER FL DISPLAY MODE
	PLAY	C	1	3	1	:	2	3	:	4	5	
		D	V	D	T	1	2	C	1	3		UNDER FL DISPLAY MODE
	PAUSE	C	1	3	1	:	2	3	:	4	5	
		D	V	D	T	1	2	C	1	3		UNDER FL DISPLAY MODE
	SEARCH	C	2		-	:	-	-	:	-	-	
		D	V	D	T	1	2	C	1	4		UNDER FL DISPLAY MODE
	+10 KEY INPUT	C	1	-	1	:	2	3	:	4	5	Blink display (ON : 0.5s / OFF : 0.5s)
		D	V	D	T	1	2	C	1	-		UNDER FL DISPLAY MODE
	TITLE+10 KEY INPUT	T	1	-	1	:	2	3	:	4	5	Blink display (ON : 0.5s / OFF : 0.5s)
		D	V	D	T	1	-	C	1	3		UNDER FL DISPLAY MODE
	REPEAT TITLE	C	2		0	:	0	0	:	0	0	
	REPEAT CHAPTER	C	2		0	:	0	0	:	0	0	
	REPEAT A-B	C	2		0	:	0	0	:	0	0	
	PROGRAM (NO ENTRY)		P	R	O	G	R	A	M			
	PROGRAM (STOP)	P	1		T	1	C				1	
	PROGRAM (PLAY)	C	1		0	:	0	1	:	2	3	
	RANDOM (STOP)		R	A	N	D	O	M				
	RANDOM (SEARCH)	T	x	x	-	:	-	-	:	-	-	
	RANDOM (PLAY/PAUSE)	T	0	1	1	:	2	3	:	4	5	
	REGION CODE ERROR	R	E	G	I	O	N	E	R	R	.	
	RESUME		R	E	S	U	M	E				

No.	Function	FL display										Note		
10	VCD (SVCD)												Total time is displayed. After 4 seconds EACH-displays. Blink display (ON : 0.5s / OFF : 0.5s)	
	STOP	V	C	D	1	2		4	8	:	1	2		
	SELECT (PBC DISC)	V	C	D						P	B	C		
	PLAY (PBC DISC)	V	C	D	1					P	B	C		
	SEARCH (PBC DISC)	V	C	D	1					P	B	C		
	PLAY (NORMAL)	V	C	D	1				0	:	2	3		
	SEARCH (NORMAL)	V	C	D	1				-	:	-	-		
	+10 KEY INPUT	V	C	D	1	-			0	:	2	3		
	PROGRAM (NO ENTRY)						P	R	O	G	R	A		M
	PROGRAM (STOP)	P			1							3		
	PROGRAM (PLAY)	V	C	D	3				1	:	2	3		
	RANDOM (STOP)						R	A	N	D	O	M		
	RANDOM (SEARCH)	V	C	D	x	x			-	-	:	-		-
	RANDOM (PLAY/PAUSE)	V	C	D	1				0	:	2	3		
	REPEAT ALL	V	C	D	1				0	:	2	3		
	REPEAT 1	V	C	D	1				0	:	2	3		
REPEAT A-B	V	C	D	1				0	:	2	3			
RESUME						R	E	S	U	M	E			
11	CD												Total time is displayed. After 4 seconds EACH-displays. Blink display (ON : 0.5s / OFF : 0.5s)	
	STOP	C	D	1	2			4	8	:	1	2		
	PLAY	C	D	1					0	:	2	3		
	SEARCH	C	D	1					-	:	-	-		
	+10 KEY INPUT	C	D	1	-				0	:	2	3		
	RANDOM (STOP)						R	A	N	D	O	M		
	RANDOM (SEARCH)	C	D	x	x			-	-	:	-	-		
	RANDOM (PLAY/PAUSE)	C	D	1					0	:	2	3		
	PROGRAM (NO ENTRY)						P	R	O	G	R	A		M
	PROGRAM (STOP)	P			1							1		
	PROGRAM (PLAY)	C	D	1					1	:	2	3		
	REPEAT ALL	C	D	1					0	:	2	3		
	REPEAT 1	C	D	1					0	:	2	3		
REPEAT A-B	C	D	1					0	:	2	3			

No.	Function	FL display										Note		
12	MP3											The light is always switched on at the time of MP3. UNDER FL DISPLAY MODE Blink display (ON : 0.5s / OFF : 0.5s) UNDER FL DISPLAY MODE Blink display (ON : 0.5s / OFF : 0.5s) UNDER FL DISPLAY MODE		
	STOP	T	R			1			0	:	0		0	
		M	P	3		G	1	2	T	1	2		3	
	PLAY	T	R	1	2	3			2	3	:		4	5
		M	P	3		G	1	2	T	1	2		3	
	SEARCH	T	R	1	2	4			-	-	:		-	-
	+10 KEY INPUT	T	R		1	-			2	3	:		4	5
		M	P	3		G	1	2	T		1		-	
	GROUP+10 KEY INPUT	G	1	-					2	3	:		4	5
		M	P	3		G	1	-	T	1	2		3	
	REPEAT ALL	T	R	1	2	3			2	3	:		4	5
	REPEAT 1	T	R	1	2	3			2	3	:		4	5
	PROGRAM (NO ENTRY)					P	R	O	G	R	A		M	
	PROGRAM (STOP)	P		1	G		1		T					1
	PROGRAM (PLAY)	T	R			1			1		:		2	3
	RANDOM (STOP)					R	A	N	D	O	M			
	RANDOM (SEARCH)	T	R	x	x	x			-	-	:		-	-
	RANDOM (PLAY/PAUSE)	T	R			1			1		:		2	3
	WMA													
	STOP	T	R			1			0	:	0		0	
	W	M	A		G	1	2	T	1	2	3			
PLAY	T	R	1	2	3			2	3	:	4	5		
	W	M	A		G	1	2	T	1	2	3			
SEARCH	T	R	1	2	3			-	-	:	-	-		
+10 KEY INPUT	T	R		1	-			2	3	:	4	5		
	W	M	A		G	1	2	T		1	-			
GROUP+10 KEY INPUT	G	1	-					2	3	:	4	5		
	W	M	A		G	1	-	T	1	2	3			
REPEAT ALL	T	R	1	2	3			2	3	:	4	5		
REPEAT 1	T	R	1	2	3			2	3	:	4	5		
PROGRAM (NO ENTRY)					P	R	O	G	R	A	M			
PROGRAM (STOP)	P		1	G		1		T				1		
PROGRAM (PLAY)	T	R			1			1		:	2	3		
RANDOM (STOP)					R	A	N	D	O	M				
RANDOM (SEARCH)	T	R	x	x	x			-	-	:	-	-		
RANDOM (PLAY/PAUSE)	T	R			1			1		:	2	3		

No.	Function	FL display											Note		
	JPEG														
	Under a display	J	P	G	G	1	2	F	1	2	3				
	+10 KEY INPUT	J	P	G	G	1	2	F		1	-			Blink display (ON : 0.5s / OFF : 0.5s)	
	GROUP+10 KEY INPUT	J	P	G	G	1	-	F	1	2	3			Blink display (ON : 0.5s / OFF : 0.5s)	
	MPEG4														
	STOP	T	R		1			0	:	0	0				
		A	S	F	G	1	2	T	1	2	3				
	PLAY	T	R	1	2	3	2	3	:	4	5				
		A	S	F	G	1	2	T	1	2	3			UNDER FL DISPLAY MODE	
	SEARCH	T	R	1	2	4	-	-	:	-	-				
	+10 KEY INPUT	T	R		1	-	2	3	:	4	5				
		A	S	F	G	1	2	T		1	-			Blink display (ON : 0.5s / OFF : 0.5s)	
	GROUP+10 KEY INPUT	G	1	-				2	3	:	4	5			
		A	S	F	G	1	-	T	1	2	3			Blink display (ON : 0.5s / OFF : 0.5s)	
	REPEAT ALL	T	R	1	2	3	2	3	:	4	5				
	REPEAT 1	T	R	1	2	3	2	3	:	4	5				
	PROGRAM (NO ENTRY)				P	R	O	G	R	A	M				
	PROGRAM (STOP)	P			1	G		1		T			1		
	PROGRAM (PLAY)	T	R				1			1	:	2	3		
	RANDOM (STOP)				R	A	N	D	O	M					
	RANDOM (SEARCH)	T	R	x	x	x	-	-	:	-	-				
	RANDOM (PLAY/PAUSE)	T	R			1			1	:	2	3			
Other	SCAN MODE				P	I	N	T	E	R	L	A	C	E	E,J,Ver.
					R	O	G	R	E	S	S	I	V	E	
								N	T	S	C				U Ver.
								P	A	L	P	R	O	G	
	UPGRADE				U	P	G	R	A	D	E			When DISC classification is 0x0F.	

4.2.2 FL display (Except DVD)

No.	Function	FL display	Note
1	SOURCE DVD AUX AM FM	D V D ↓ R E A D I N G A U X A M ↓ 5 3 1 k F M ↓ 1 0 3 . 5 0 M	About fine contents, it is based on DVD specification. After displaying for 2 seconds, it shifts to the following displays. After displaying for 2 seconds, it shifts to the following displays. It displays only at the time of a PRESET call. After displaying for 2 seconds, it shifts to the following displays. It displays only at the time of a PRESET call.
2	MUTING	M U T I N G	At FADE MUTING After cancel, return to normal display.
3	VOLUME UP/DOWN	V O L U M E 2 0	It displays for 5 seconds. It returns to a normal display after 5 seconds.
4	SLEEP	S L E E P 1 5 0 m i n S L E E P O F F	It displays for 5 seconds. It returns to a normal display after 5 seconds.
5	DIMMER	D I M M E R 1 2 D I M M E R 2 A U T O D I M M F D I M M E R O F F	AT PRESS DIMMER KEY(REMOCON), 5-SECOND INDICATE.
6	BASS	B A S S + 5 B A S S 0 B A S S - 5	+5 ~ 0 ~ -5
7	TREBLE	T R E B L E + 5 T R E B L E 0 T R E B L E - 5	+5 ~ 0 ~ -5
8	AM STEP	9 k S T E P 1 0 k S T E P	It displays for 5 seconds. It returns to a normal display after 5 seconds.
9	RDS DISPLAY	N O P S N O P T Y N O R T	No PS information. No PTY information. No RT information.

No.	Function	FL display	Note
10	PTY SELECTION	S E L E C T P T Y S N E W S S E A R C H N E W S F O U N D N E W S X X X X X X X X N O T F O U N D	<p>PRESS SHIFT+ON SCREEN (PTY SEARCH) SELECT and PTY will display alternatively for 500msec each.</p> <p>PRESS PTY SELECT+/- TO SELECT PTY CODE. THE SELECTED PTY CODE WILL BLINK (0.5sec ON/OFF).</p> <p>PRESS SHIFT+ON SCREEN (PTY SEARCH) to begin search. DISPLAY 'SEARCH' and PTY code each for 500msec.</p> <p>If the RDS station with the select PTY code is found. The found PTY code will blink for 8 seconds (0.5sec ON/OFF). Then, display shows the PRESET RDS station for 1 sec. Then display PS information.</p> <p>IF CANNOT FOUND, DISPLAY 'NOT FOUND' FOR 2 SEC. RETURN TO PREVIOUS DISPLAY.</p>
11	SUBWOOFER	S U B W O O F E R O F F	<p>It displays for 5 seconds. It returns to a normal display after 5 seconds.</p> <p>It displays for 5 seconds. It returns to a normal display after 5 seconds.</p>
12	DVD LEVEL	N O R M A L L E M I D D L E H I G H	<p>AT PRESS DVD LEVEL KEY(REMOCON), 5-SECOND INDICATE.</p>
13	AUTO STANDBY	A . S T A N D B Y	<p>AT PRESS AUTO STANDBY KEY(REMOCON), 5-SECOND INDICATE.</p>

SECTION 5 TROUBLESHOOTING

This service manual does not describe TROUBLESHOOTING.



JVC

Victor Company of Japan, Limited
AV & MULTIMEDIA COMPANY AUDIO/VIDEO SYSTEMS CATEGORY 10-1,1chome,Ohwatari-machi,Maebashi-city,371-8543,Japan

(No.MB376)

JVC

SCHEMATIC DIAGRAMS

COMPACT COMPONENT SYSTEM

FS-Y1

CD-ROM No.SML200505

Area suffix

J----- U.S.A.
C----- Canada

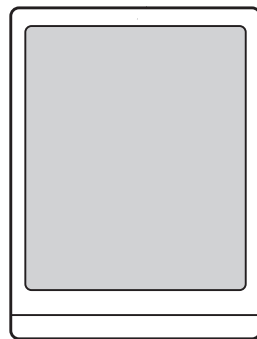
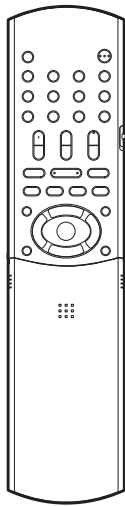

(SP-FSY1)

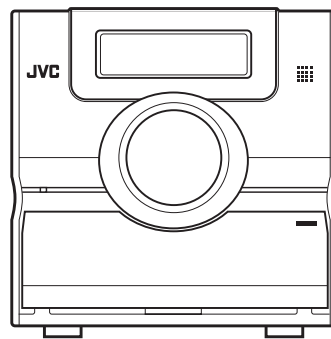

(CA-FSY1)

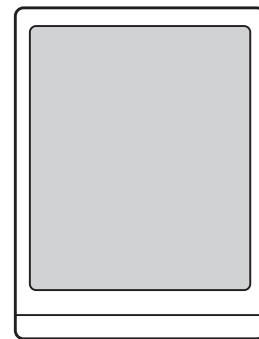

(SP-FSY1)



Lead free solder used in the board (material : Sn-Ag-Cu, melting point : 219 Centigrade)

Contents

Block diagram	2-1
Standard schematic diagrams	2-3
Printed circuit boards	2-19 to 25

In regard with component parts appearing on the silk-screen printed side (parts side) of the PWB diagrams, the parts that are printed over with black such as the resistor (■), diode (⊣) and ICP (●) or identified by the "⚠" mark nearby are critical for safety.

< MEMO >

Block diagram

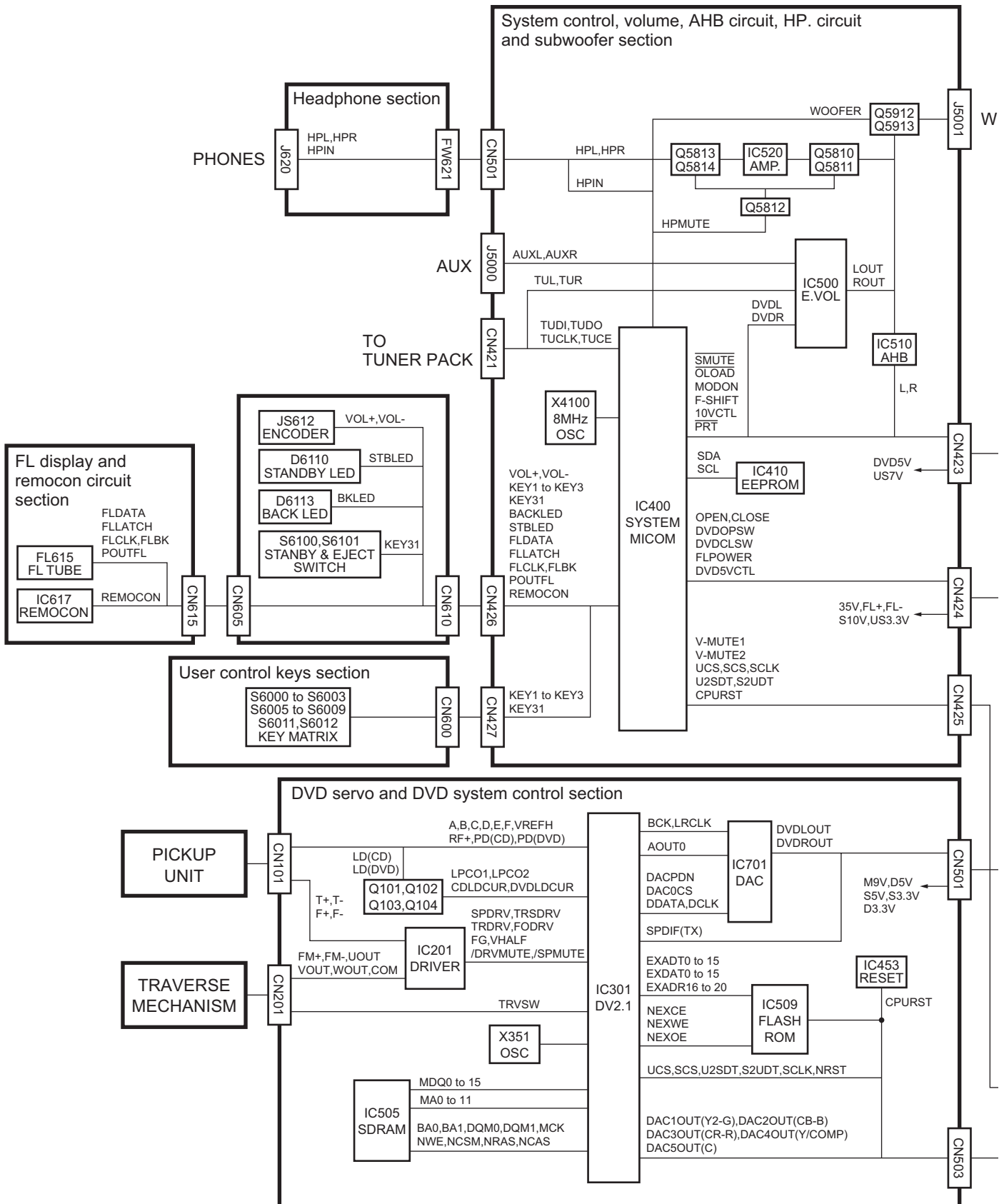

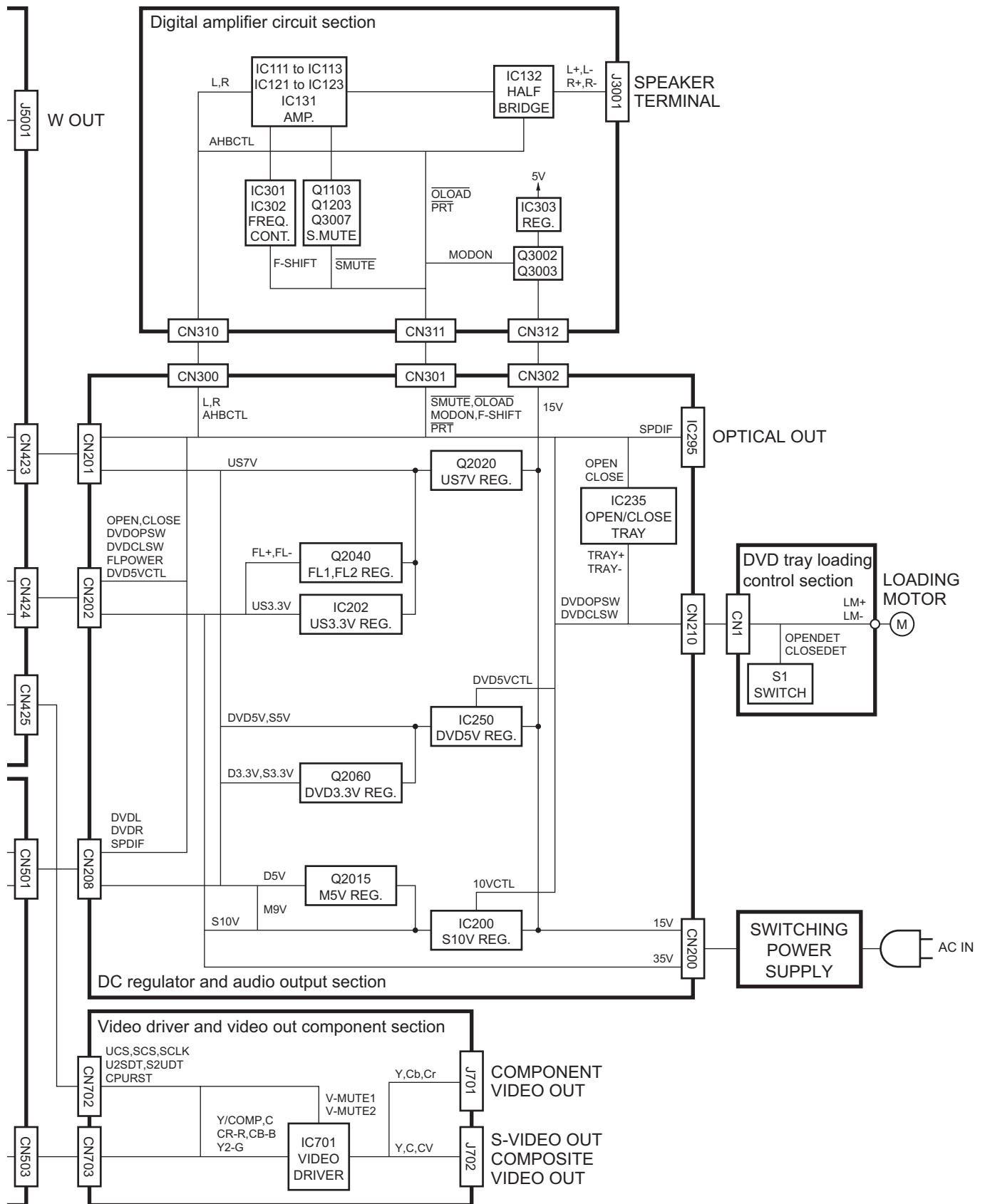

Standard schematic diagrams

DC regulator and audio output section

(SHEET 2)

TO CN312 OF
GVA10099-A2

TO CN1 (SHEET 8)
TO DVD OPEN/CLOSE TRAY

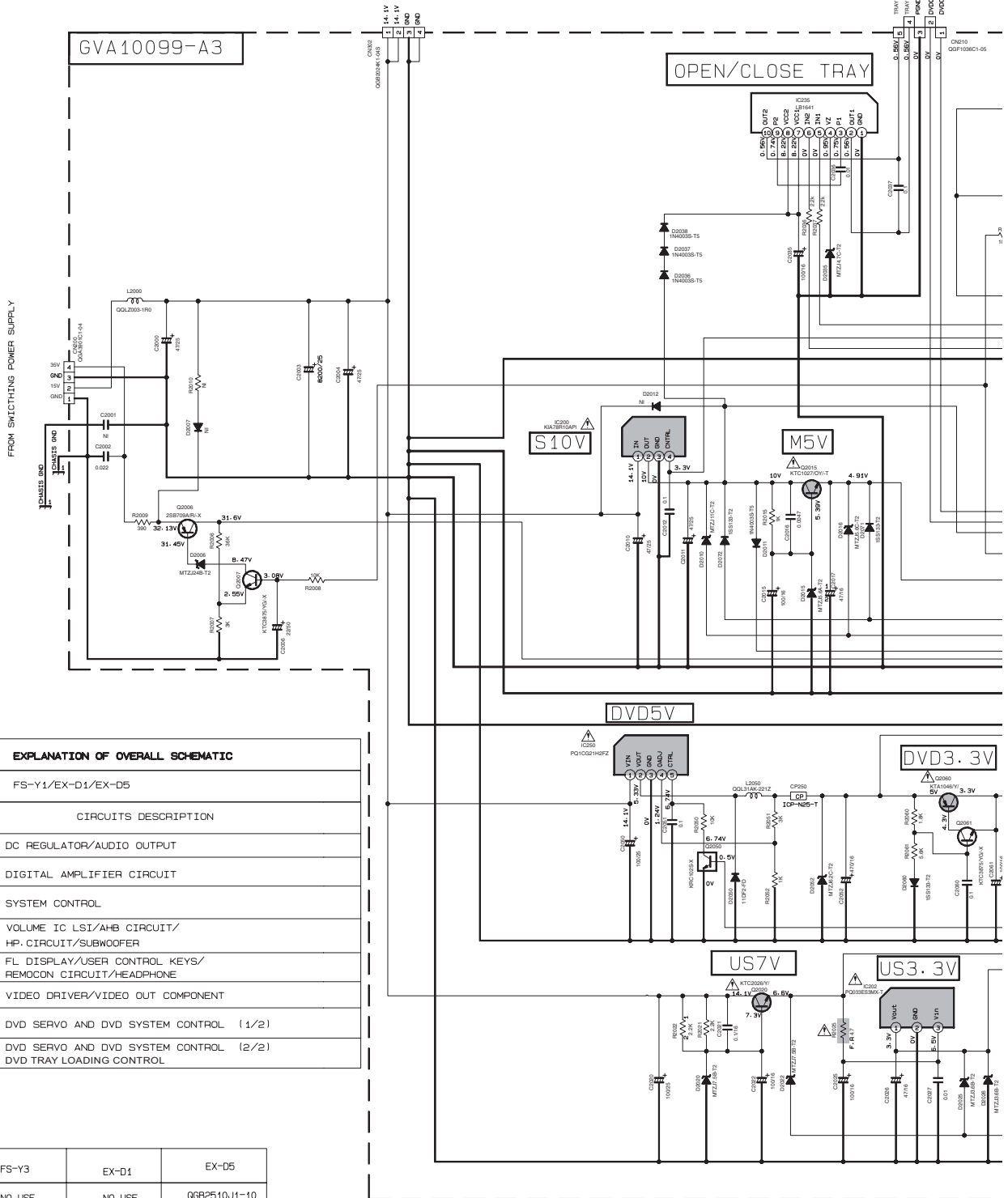

EXPLANATION OF OVERALL SCHEMATIC

EXPLANATION OF OVERALL SCHEMATIC	
MODEL	FS-Y1/EX-D1/EX-D5
SHEET NUMBER	CIRCUITS DESCRIPTION
1	DC REGULATOR/AUDIO OUTPUT
2	DIGITAL AMPLIFIER CIRCUIT
3	SYSTEM CONTROL
4	VOLUME IC LSI/AHB CIRCUIT/ HP. CIRCUIT/SUBWOOFER
5	FL DISPLAY/USER CONTROL KEYS/ REMOCON CIRCUIT/HEADPHONE
6	VIDEO DRIVER/VIDEO OUT COMPONENT
7	DVD SERVO AND DVD SYSTEM CONTROL (1/2)
8	DVD SERVO AND DVD SYSTEM CONTROL (2/2) DVD TRAY LOADING CONTROL

* MARK

MODEL	FS-Y3	EX-D1	EX-D5
REF. NO	NO USE	NO USE	06B2510J1-10
CN203	NO USE	NO USE	06B2510J1-10

NOTES

- VOLTAGES ARE DC-MEASURED WITH A DIGI CONDITION-CD STOP MODE



/CLOSE TRAY

TO CN310 OF
GVA10099-A2

TO CN311 OF
GVA10099-A2

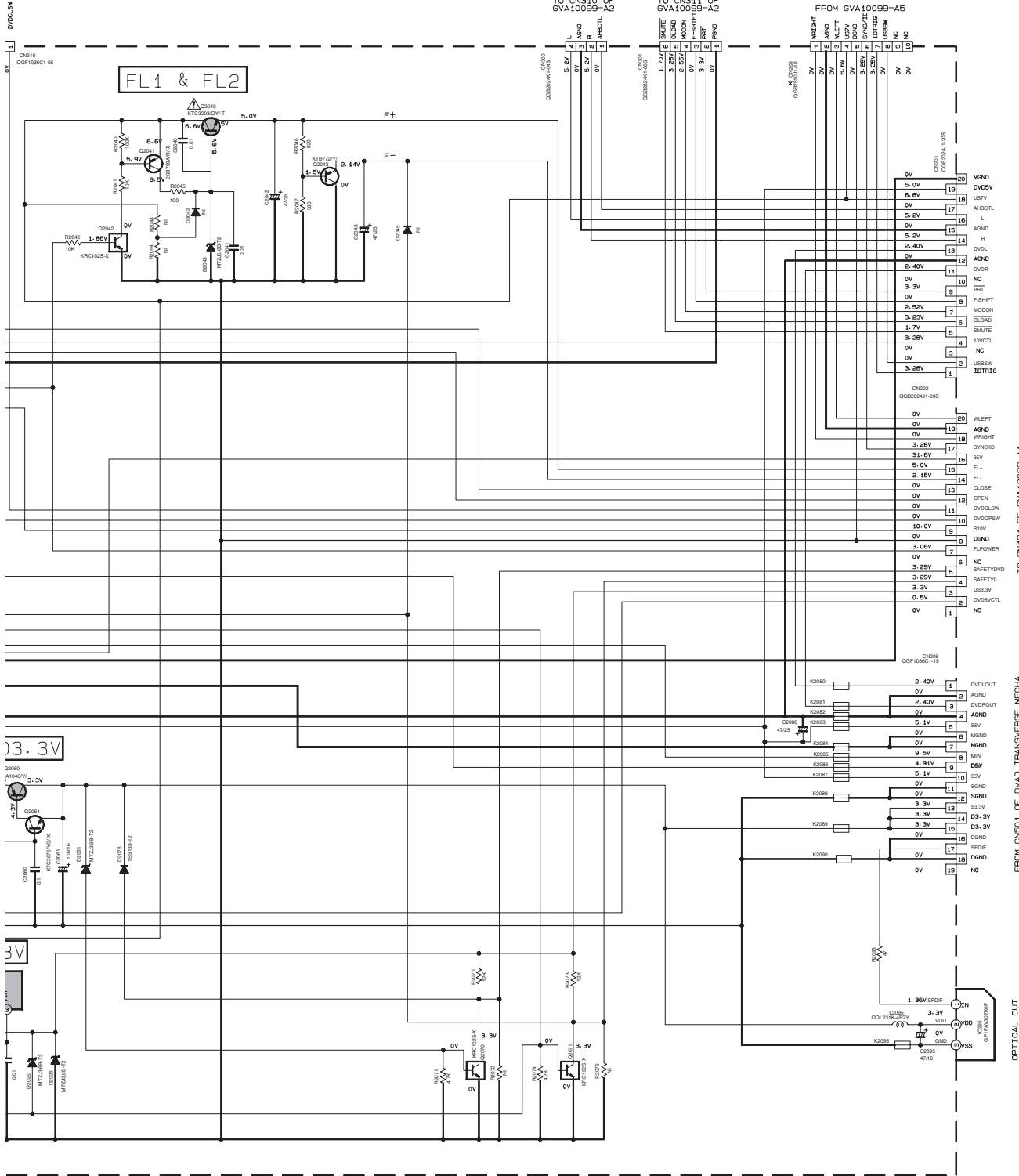

TO CN423 OF GVA10099-A1
(SHEET 3)

TO CN424 OF GVA10099-A1
(SHEET 3)

FROM CN201 OF DVAD TRANSVERSE MECHA
(SHEET 8)

WITH A DIGITAL VOLT METER WITHOUT INPUT SIGNAL 2- UNLESS OTHERWISE SPECIFIED.

RESISTORS ARE 1/16W±5% METAL GLAZE RESISTOR.
 ALL RESISTANCE VALUES ARE IN OHM (Ω).
 ALL CAPACITORS ARE CERAMIC CAPACITOR OR MYLAR CAPACITOR.
 ALL CAPACITANCE VALUES ARE IN nF (P=PF).
 ALL INDUCTANCE VALUES ARE IN μH (M=MH).
 ALL E₂ CAPACITORS ARE SHOWN IN THE FORM RESET OF INH CAPACITANCE (nF)/RATED VOLTAGE (V).

⚠ Parts are safety assurance parts.
 When replacing those parts make
 sure to use the specified one.

Digital amplifier circuit section

(SHEET 1)

FROM CN300 OF 0V410099-43

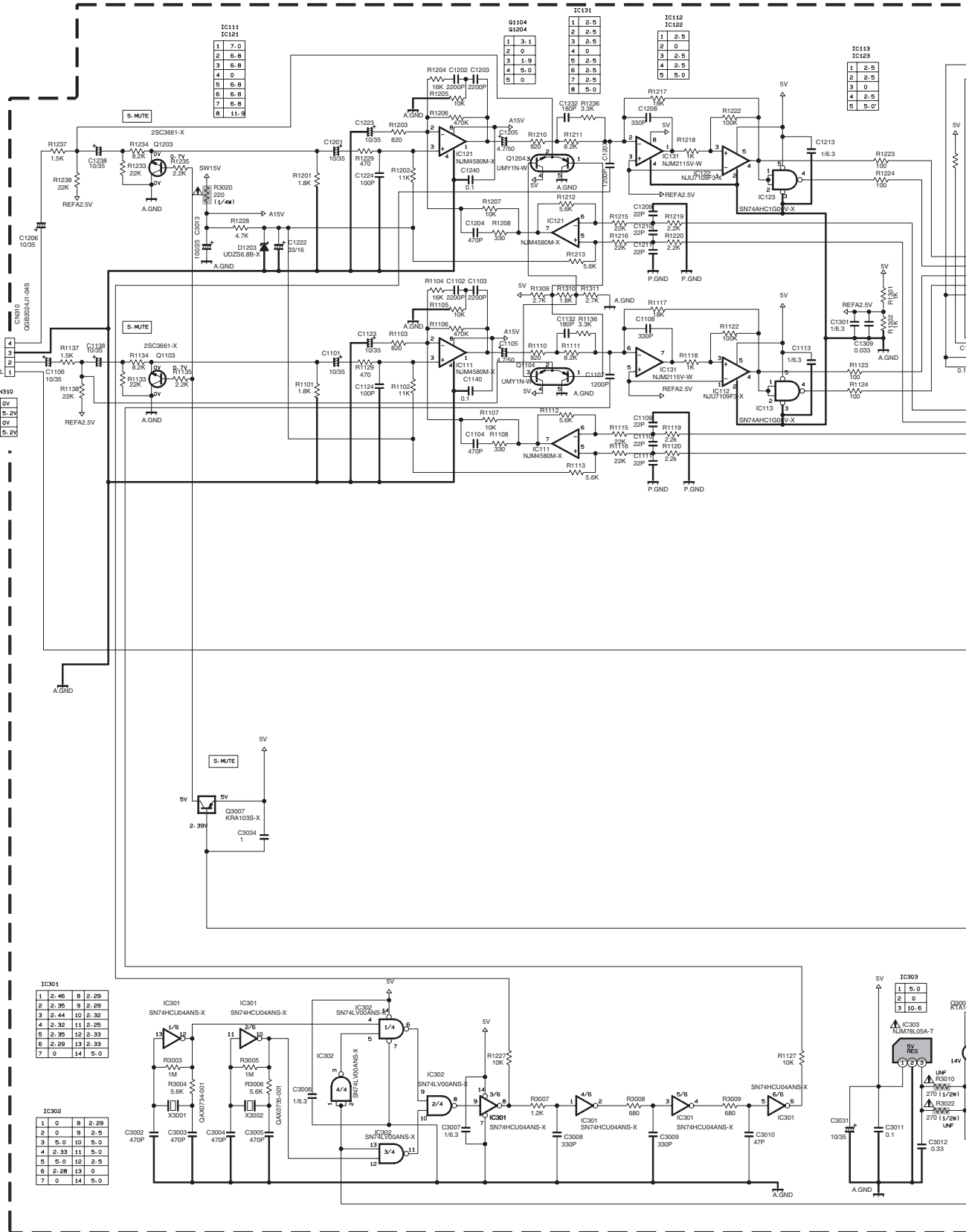

NOTES

1. VOLTAGES ARE CD-MEASURED WITH A DIGITAL VOLT METER WITHOUT INPUT SIGNAL. CONDITION-CD STOP MODE.
2. UNLESS OTHERWISE SPECIFIED, RESISTORS ARE 1/4W/5% METAL GLAZERESISTOR. ALL RESISTANCE VALUES ARE IN OHM (Ω). ALL CAPACITORS ARE CERAMIC CAPACITOR OR MYLAR C. ALL CAPACITANCE VALUES ARE IN pF (pF). ALL INDUCTANCE VALUES ARE IN μH (μH). ALL E-CAPACITORS ARE SHOWN IN THE FORM RESET OF IN (μF)/RATED VOLTAGE (V).



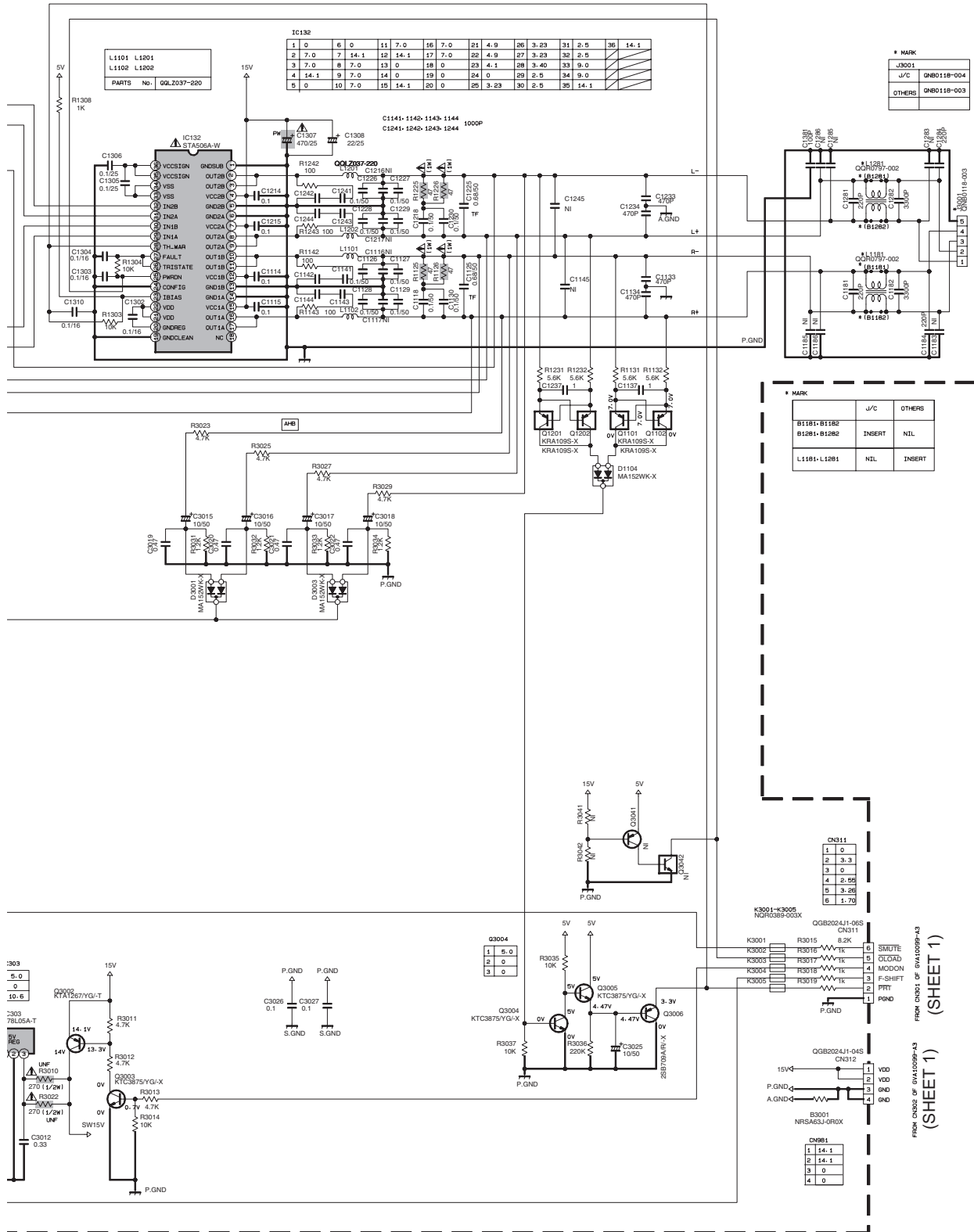

⚠ Parts are safety assurance parts.
When replacing those parts make
sure to use the specified one.

3TOR.
3 OR MYLAR CAPACITOR.
1 RESET OF INH CAPACITANCE

System control section

Ver. E

TO CN201
(SHEET 1)
CN423 OGB2024K1-20S

YVND	0V
US7V	5.0V
AHBCCTL	0V
L	L 5.2V
R	R 5.2V
DVDL	DVDL2 4V
AGND	0V
DVDR	DVDR2 4V
(PGND) NC	0V
PRT	PRT 3.3V
F-SHIFT	F-SHIFT 0V
MODCN	MODCN 0V
QLOAD	QLOAD 2.2V
SMUTE	SMUTE 0V
10VCTL	10VCTL 3.2V
STANDBY	STANDBY 0V
USBW	USBW 3.2V
IDTRIG	IDTRIG 0V

TO CN202
(SHEET 1)
CN424 OGB2024K1-20S

WLEFT	0V
AGND	0V
RIGHT	WRIGHT 0V
SYNCD	SYNCD 3.2V
FL+	FL+ 5.0V
FL-	FL- 2.10V
CLOSE	CLOSE 0V
OPEN	OPEN 0V
DVDCLSW	DVDCLSW 0V
DVDPSW	DVDPSW 10.0V
S10V	0V
DND	0V
FLOWER	FLOWER 0V
SAFETYDVB	SAFETYDVB 3.2V
SAFETY0	SAFETY0 3.2V
US3.3V	0V
DVDSVCTL	DVDSVCTL 0V
NC	0V

TO CN702
(SHEET 6)
CN425 OGB1214J1-12S

V-MUTE1	V-MUTE1 3.15V
NC	0V
V-MUTE2	V-MUTE2 3.15V
VND	0V
DVD6V	5.0V
UCS	UCS 3.36V
SCLK	SCLK 3.36V
US2D	US2D 3.36V
S2UDT	S2UDT 3.29V
CPURS	CPURS 5.21V
DND	0V



- NOTES
- VOLTAGES ARE DC-MEASURED WITH A DIGITAL VOLT METER OR OSCILLOSCOPE WITHOUT INPUT SIGNAL. CONDITION --- CD STOP MODE Vol.0
 - UNLESS OTHERWISE SPECIFIED RESISTORS ARE 63mW ±5% CARBON RESISTOR. ALL RESISTANCE VALUES ARE IN OHM(Ω). ALL CAPACITORS ARE CERAMIC CAPACITOR OR MYLAR CAPACITOR. ALL CAPACITANCE VALUES ARE IN pF(pF). ALL INDUCTANCE VALUES ARE IN mH(mH). ALL E-CAPACITORS ARE SHOWN IN THE FORM OF CAPACITANCE (μF)/RATED VOLTAGE (V). ALL DIODES ARE MA111-X
 - MARK(* AND #) IS TO SHOW DEVIATION IN VERSIONS ARE EXPLAINED NEAR MARK

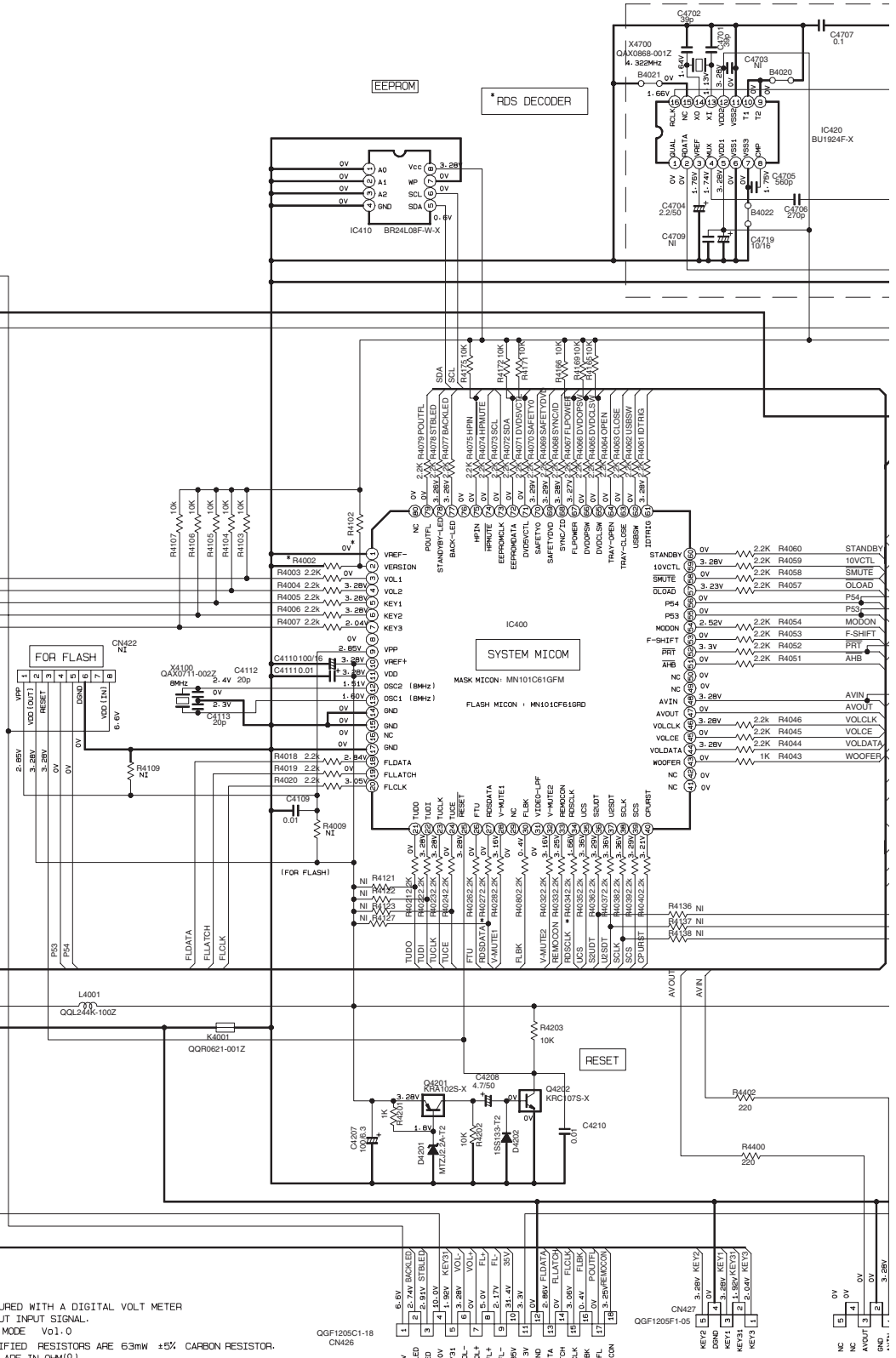

TO CN610 (SHEET 5)

TO CN600
(SHEET 5)

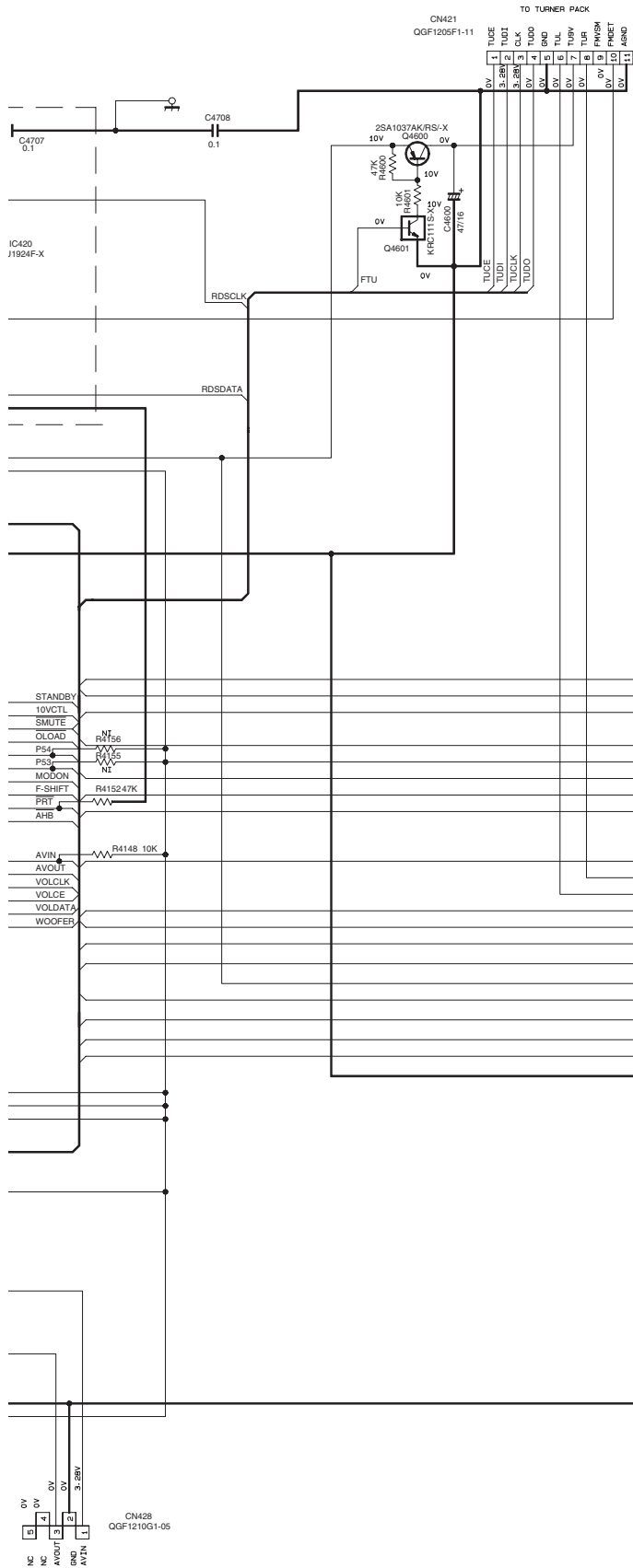

MARK *

MODEL	EX-D1	EX-D5	FS-Y1
RDS DECODER	USE	USE	NONE
R4027 (RDSDATA)	USE	USE	NONE
R4034 (RDSCLK)	USE	USE	NONE

MARK *

VERSION	R4102	R4002
J/C	10K	3.6K
U1	10K	8.2K
U2	10K	16K
U3	10K	39K
U4	10K	NONE
E	NONE	10K

(SHEET 4)

Volume, AHB circuit, HP. circuit and subwoofer section

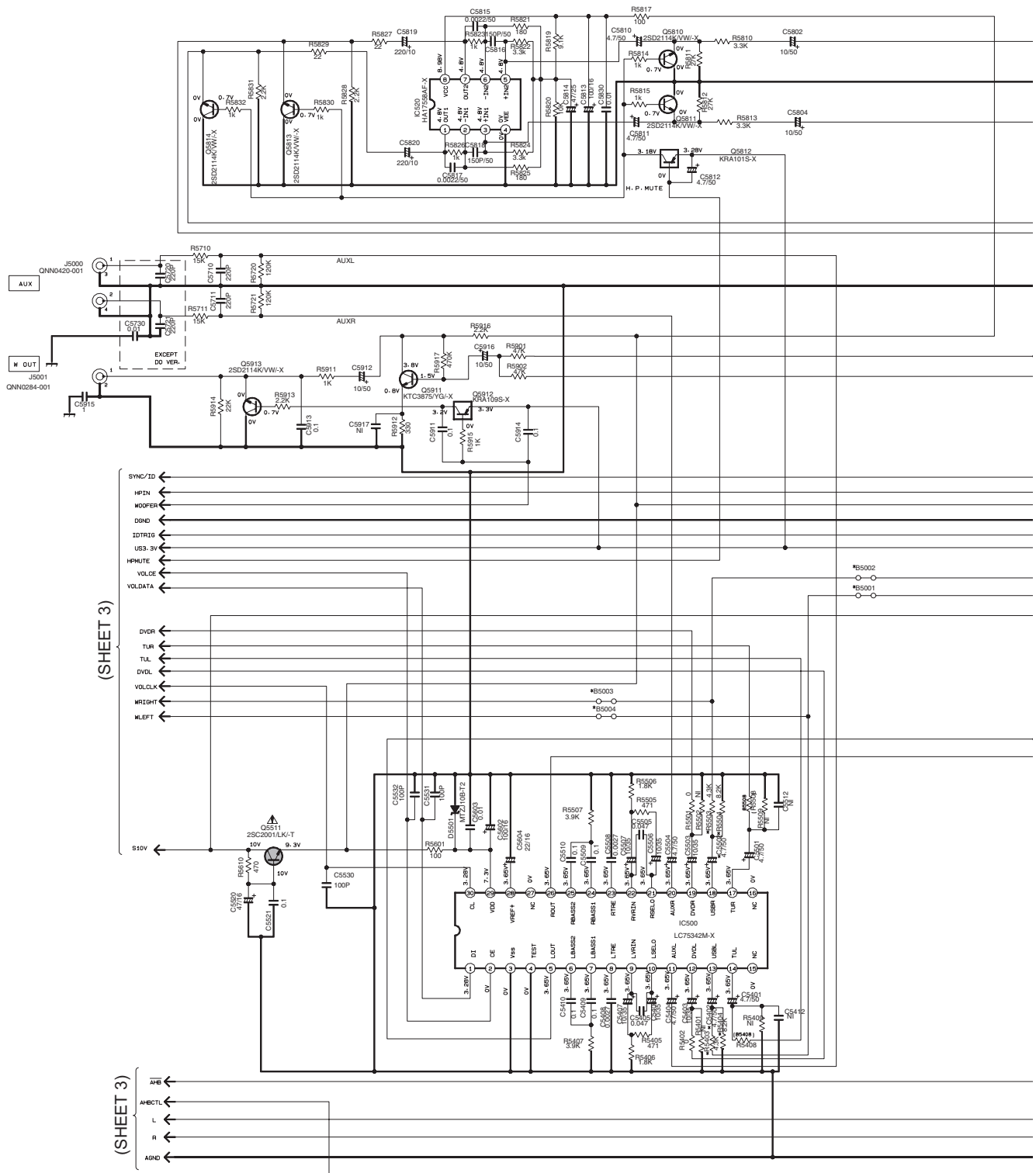

(SHEET 3)

(SHEET 3)

MARK *

	EX-01	EX-05	FS-Y1
B5001	USE	NONE	NONE
B5002	USE	NONE	NONE
B5003	NONE	USE	NONE
B5004	NONE	USE	NONE
R5403	4.3K	4.3K	NONE
R5404	8.2K	8.2K	NONE
R5503	4.3K	4.3K	NONE
R5504	8.2K	8.2K	NONE
C5402	4.7/50	4.7/50	NONE
C5502	4.7/50	4.7/50	NONE

TO FW621 (SHEET 5)

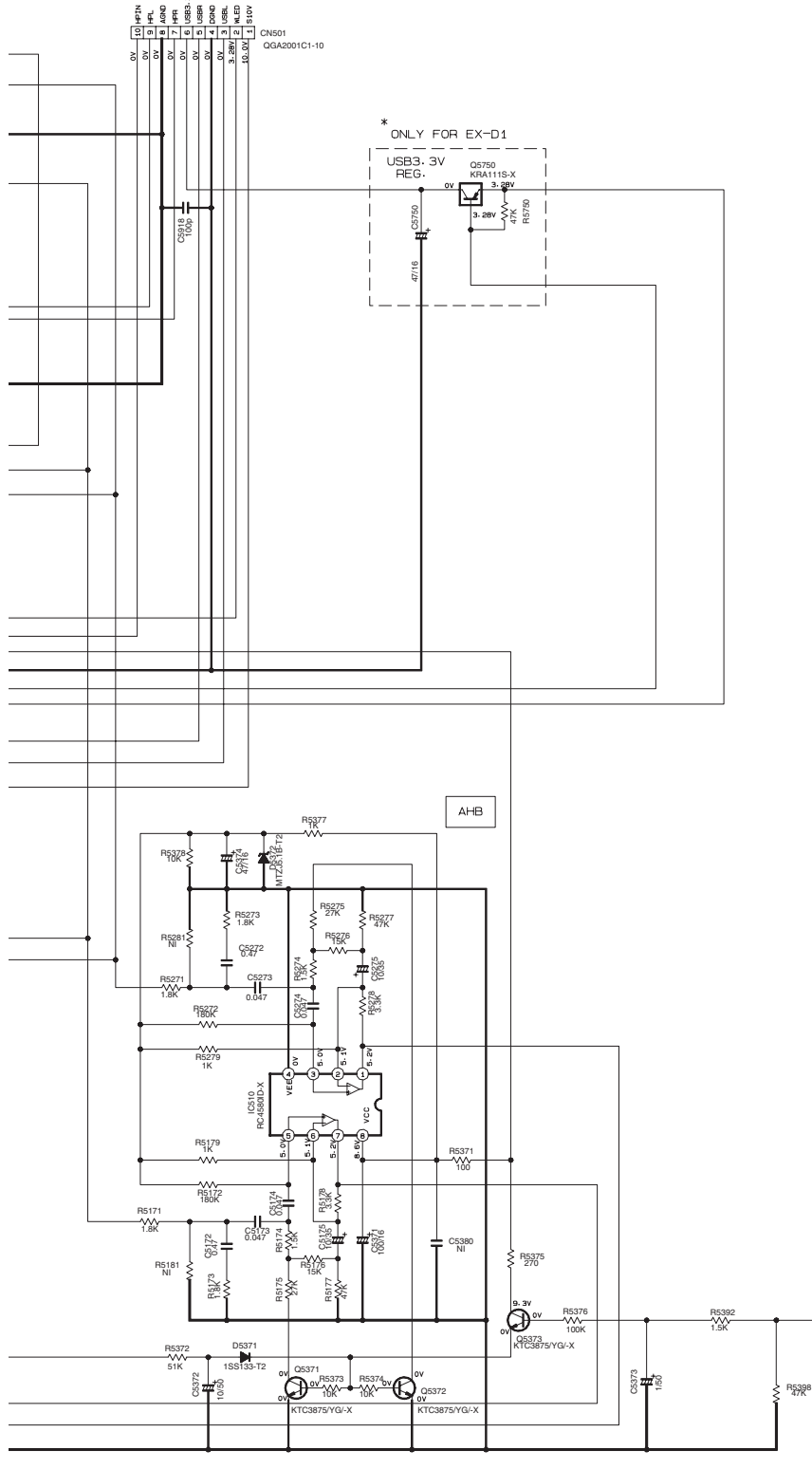

NOTES

1. VOLTAGES ARE DC-MEASURED WITH A DIGITAL VOLT METER OR OSCILLOSCOPE WITHOUT INPUT SIGNAL.
CONDITION: CD STOP MODE
2. UNLESS OTHERWISE SPECIFIED.
 - ALL RESISTANCE VALUES ARE IN OHM(Ω).
 - ALL CAPACITORS ARE CERAMIC CAPACITOR OR MYLAR CAPACITOR.
 - ALL CAPACITANCE VALUES ARE IN #F(=PF).
 - ALL INDUCTANCE VALUES ARE IN #H(=MH).
 - ALL S-CAPACITORS ARE SHOWN IN THE FORM OF CAPACITANCE (#F)/RATED VOLTAGE (V).
 - ALL DIODES ARE 1S8133-T2



Parts are safety assurance parts. When replacing those parts make sure to use the specified one.

FL display, user control keys, remocn circuit and headphone section

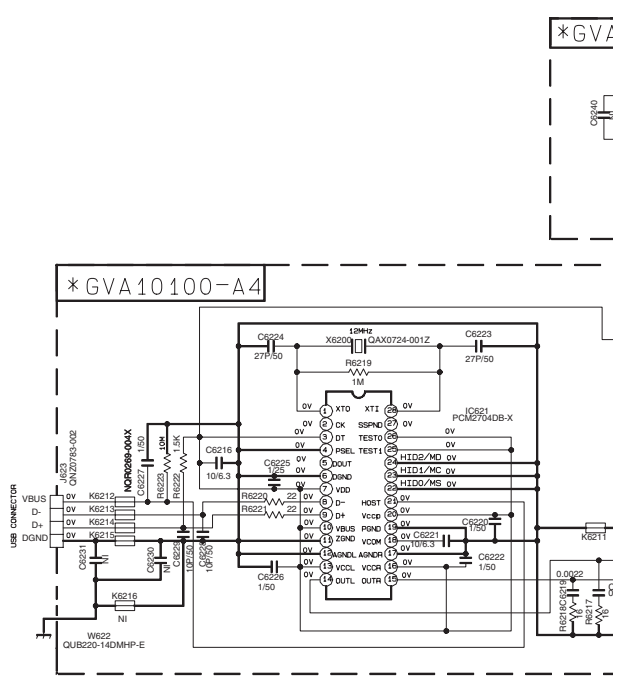
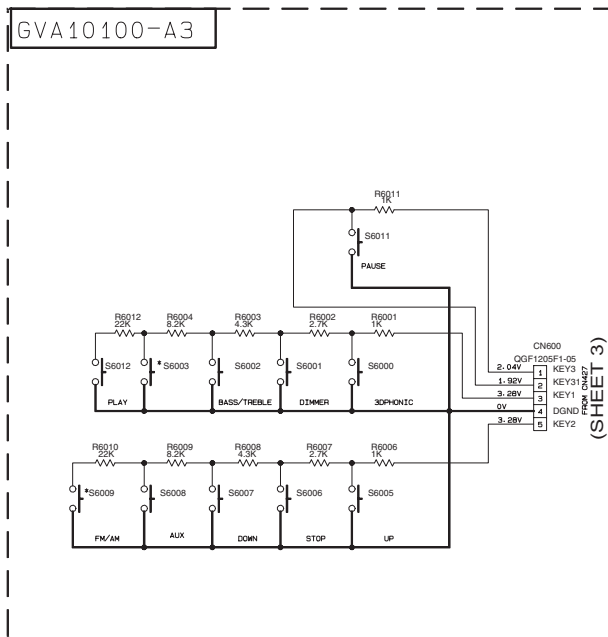
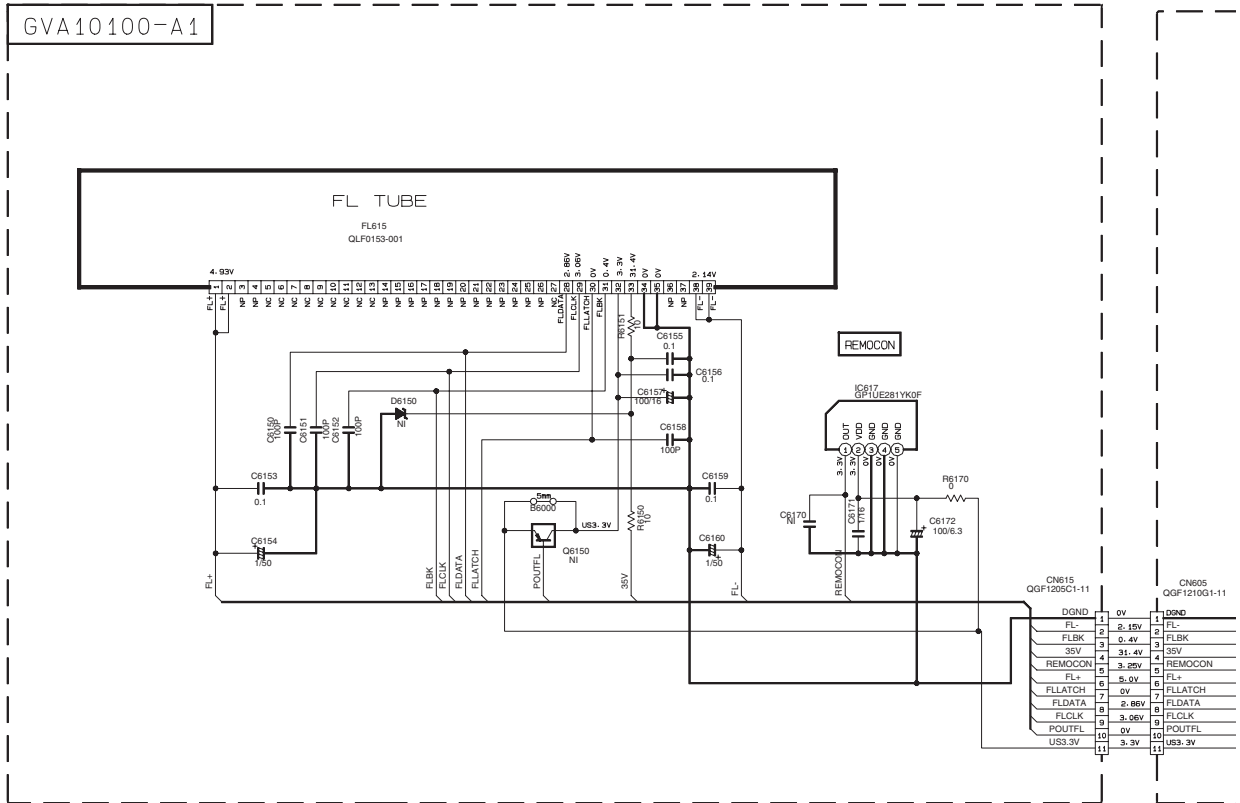

MARK *

MODEL	EX-D1	EX-D5	FS-Y1
S6003	USB	WIRELESS	FM
S6009	FM/AM	FM/AM	AM
FB105	B. BK	3PK	NONE
KB218	GGP0601-0012	NONE	NONE
BB050	NONE	QUY150-050Y	QUY150-050Y
BB340, BB341, BB342, BB343	QUY158-078Y	NONE	NONE
GVA10100-A4	USE	NONE	NONE
GVA10100-A6	NONE	USE	NONE
FW621	QJK043-101520-E	QJK043-101520-E	QJK043-041520-E

- NOTES
- VOLTAGES ARE DC-MEASURE OR OSCILLOSCOPE WITHOUT CONDITION --- CD STOP MDI
 - UNLESS OTHERWISE SPECIFI ALL RESISTANCE VALUES AR ALL CAPACITORS ARE CERAM ALL CAPACITANCE VALUES A ALL INDUCTANCE VALUES AR ALL E. CAPACITORS ARE SHD OF CAPACITANCE (μF)/RATE ALL DIODES ARE MA111-X
 - MARK(* AND #) IS TO SHOW ALL SWITCHES ARE GSW1

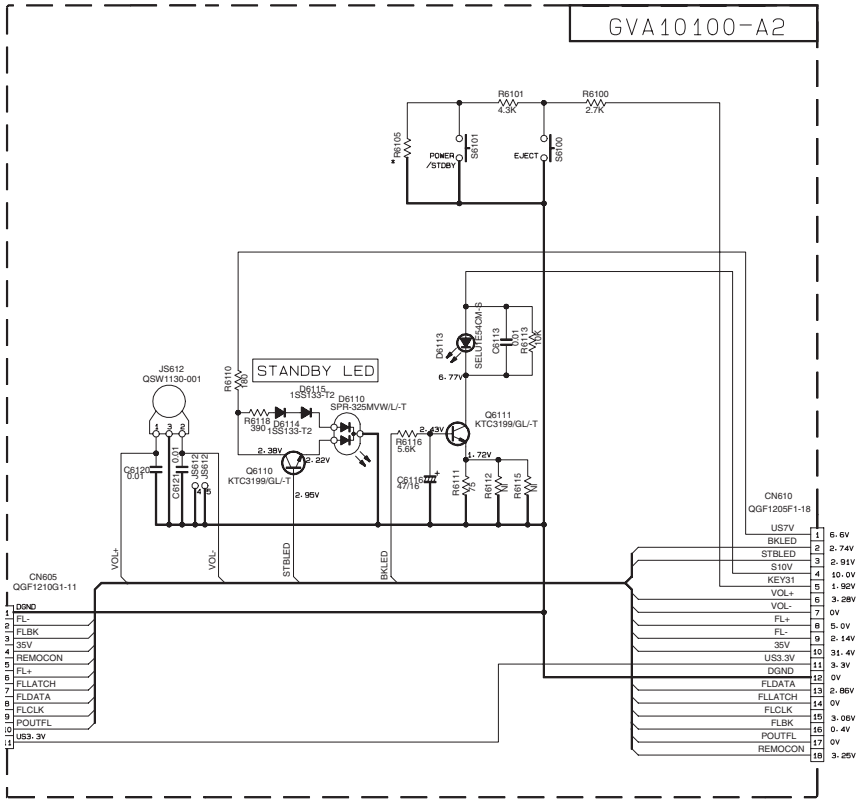

FROM QMPS
(SHEET 3)

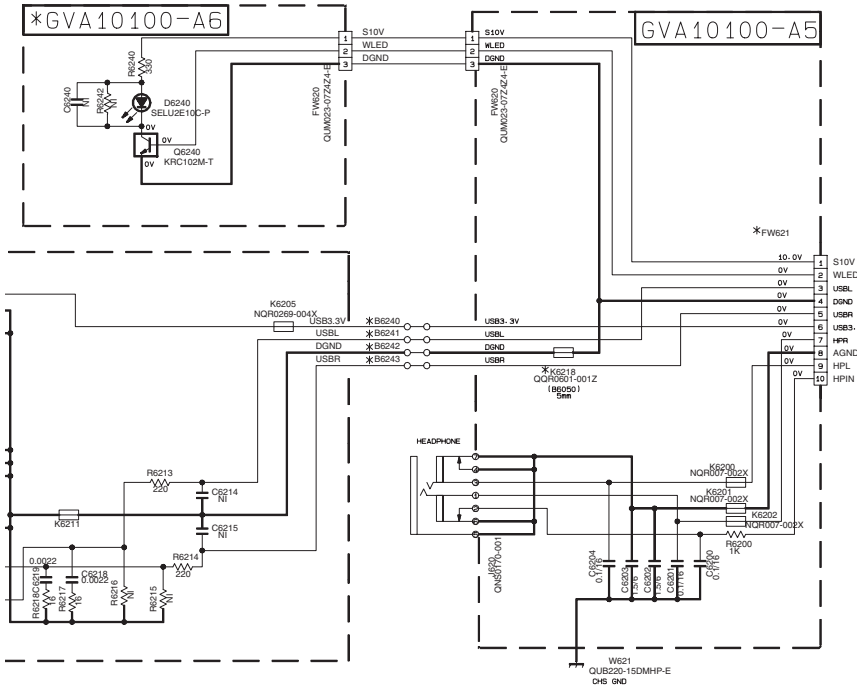

FROM QM61
(SHEET 4)

*E DC-MEASURED WITH A DIGITAL VOLT METER
 *D/CPE WITHOUT INPUT SIGNAL.
 — CD STOP MODE Vo1.0
 *RWISE SPECIFIED RESISTORS ARE 1/BW ±5% CARBON RESISTOR.
 *NCE VALUES ARE IN ◻(M(H)).
 *ORS ARE CERAMIC CAPACITOR OR MYLAR CAPACITOR.
 *ANCE VALUES ARE IN #I(P(PpF)).
 *NCE VALUES ARE IN #H(M(MH)).
 *ITORS ARE SHOWN IN THE FORM
 *NCE (uP)/RATED VOLTAGE (V).
 *ARE MA111-X
 *#1 IS TO SHOW DEVIATION IN VERSIONS ARE EXPLAINED NEAR MARK.
 *ES ARE GSW1121-0012

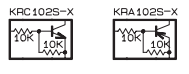

Video driver and video out component section

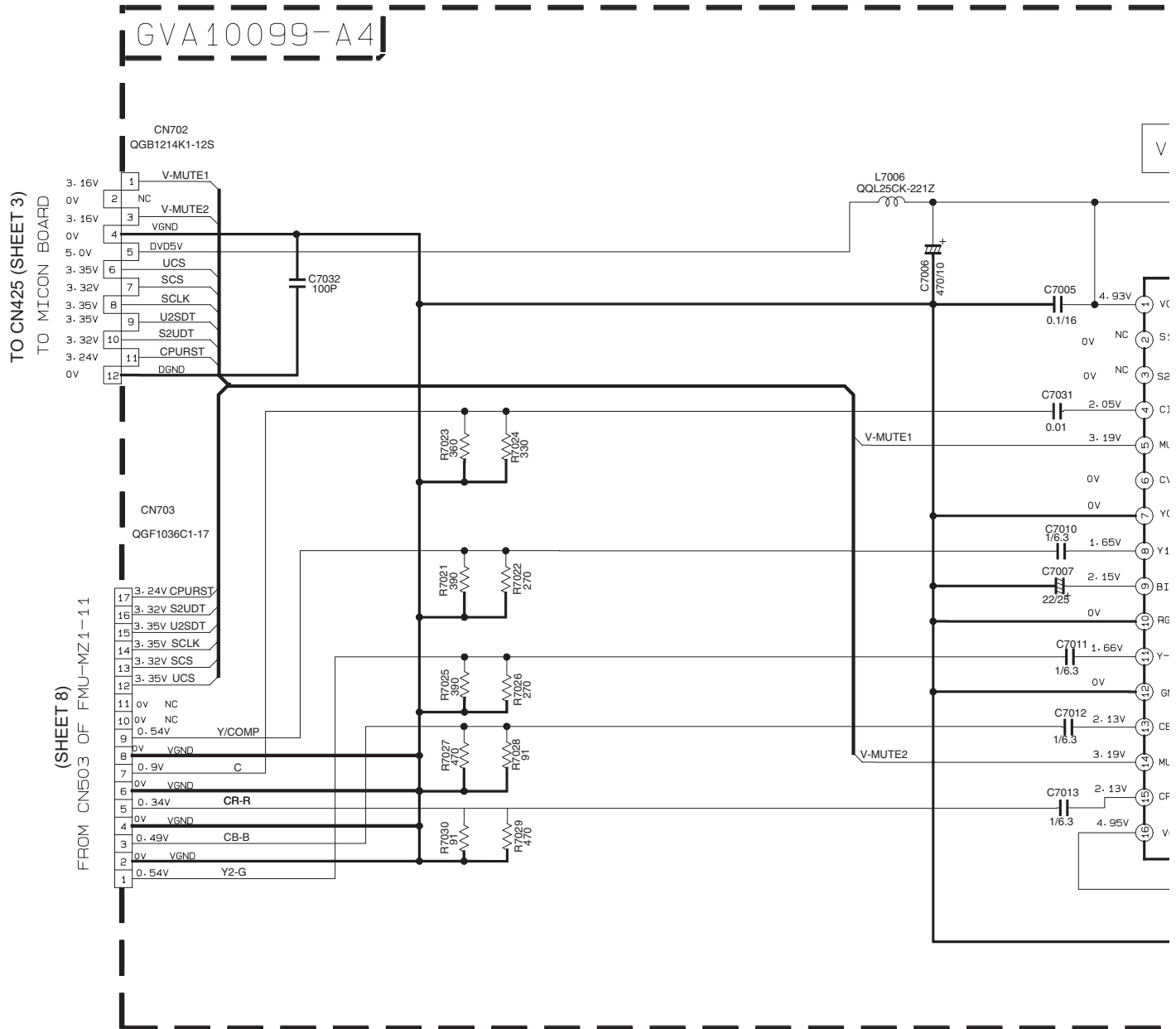

VIDEO DRIVER

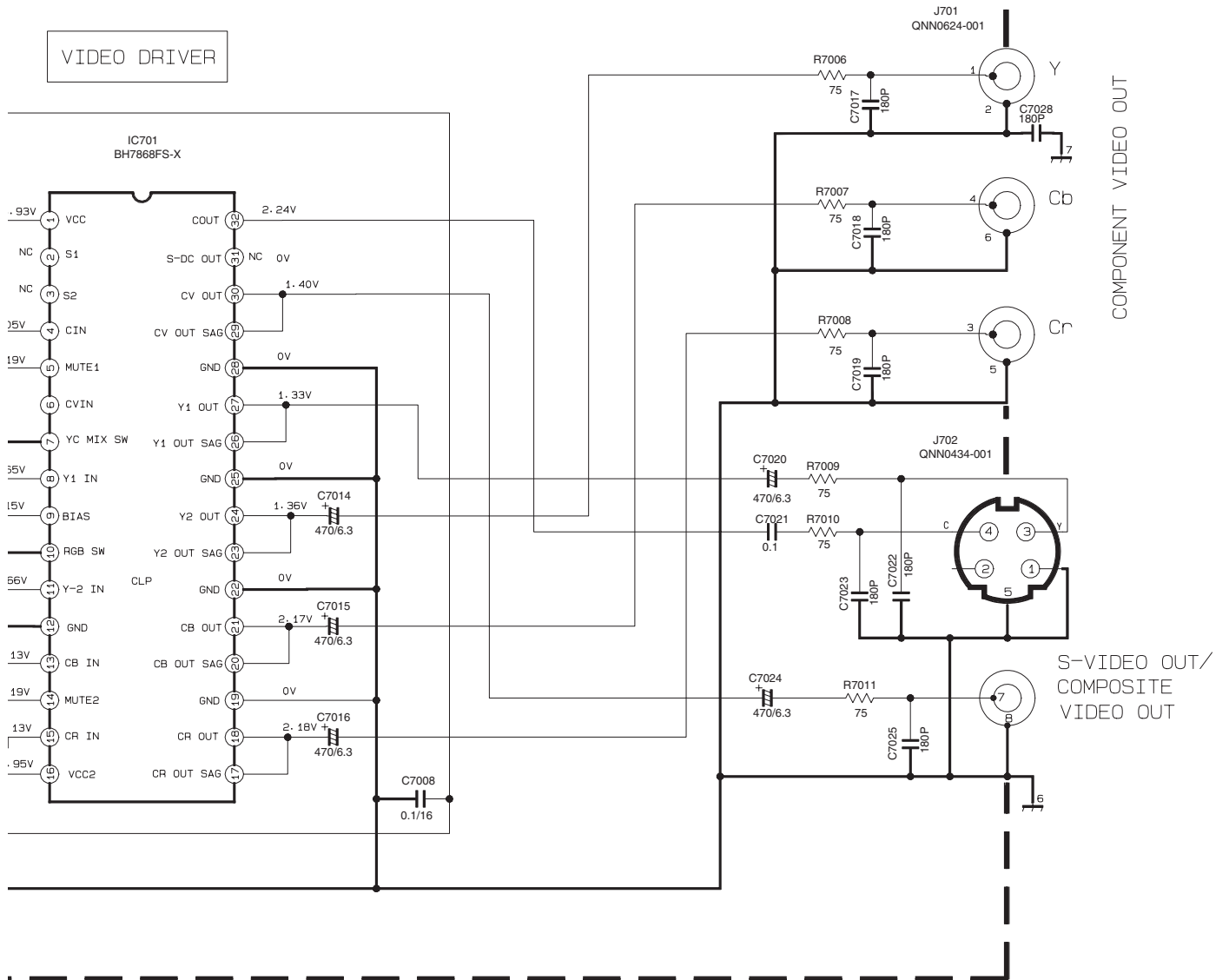

COMPONENT VIDEO OUT

S-VIDEO OUT/
COMPOSITE
VIDEO OUT

DVD servo and DVD system control section (1/2)

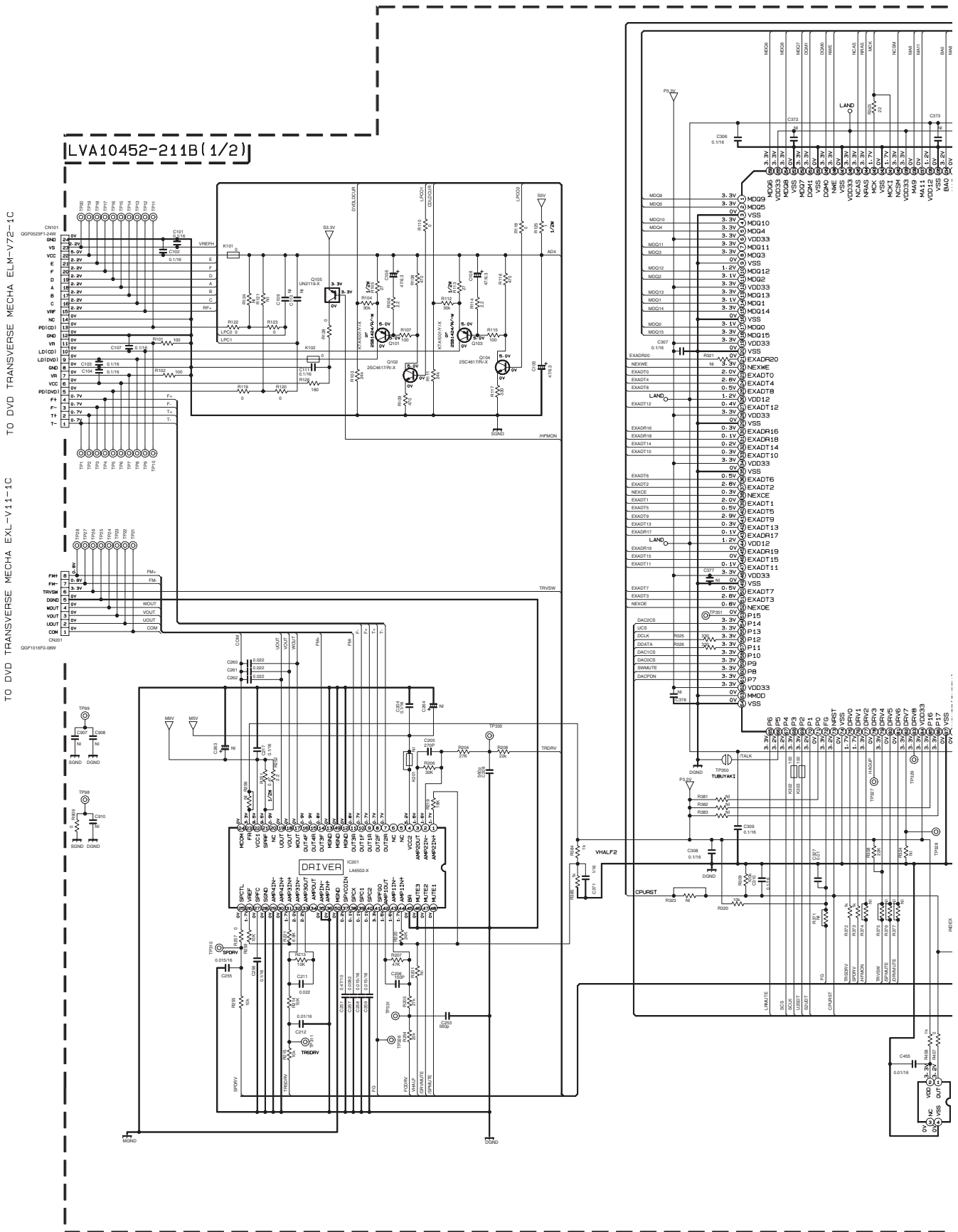

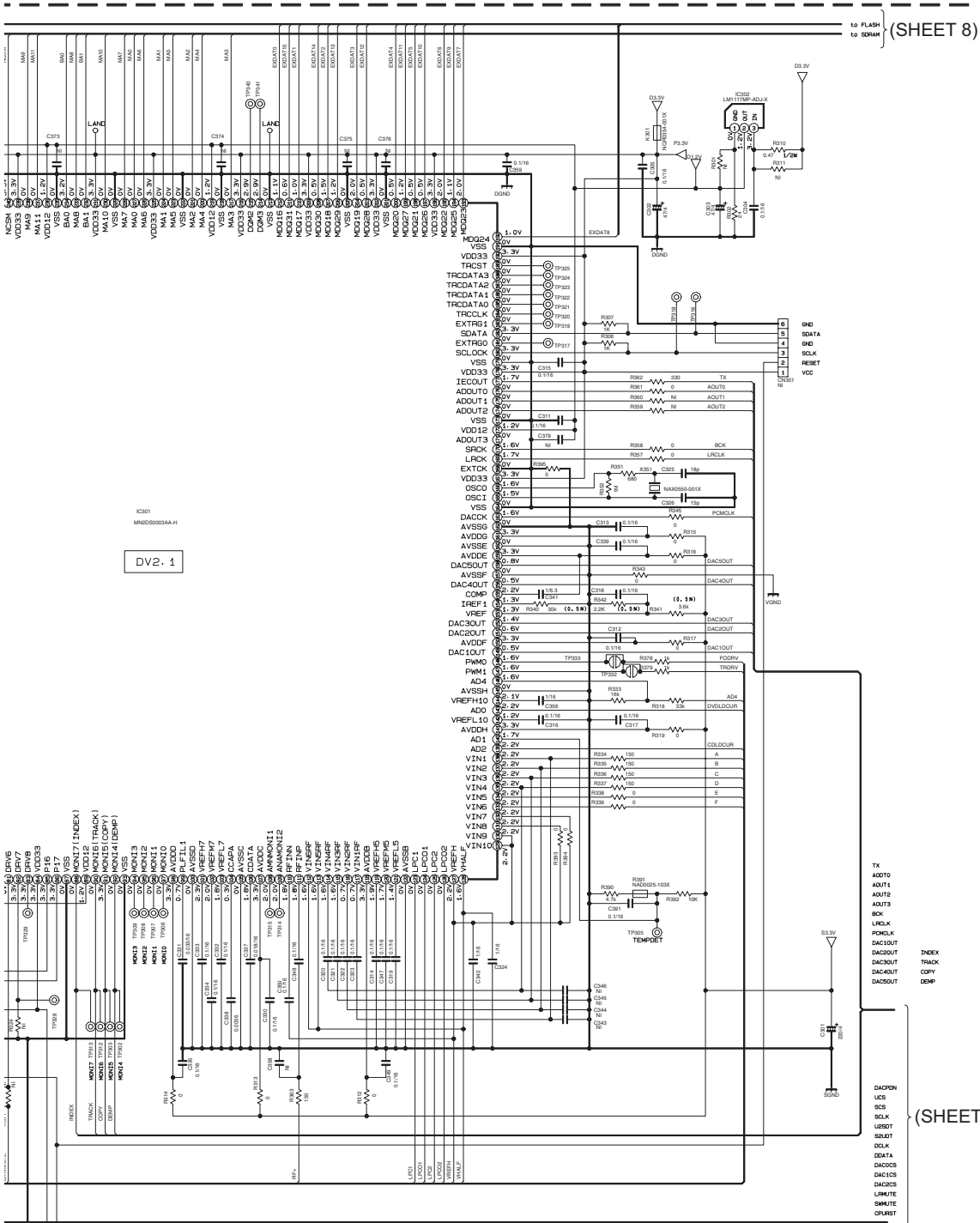

(SHEET 8)

(SHEET 8)

NOTES

1. VOLTAGES ARE DC-MEASURED WITH A DIGITAL VOLT METER WITHOUT INPUT SIGNAL. CONDITION: DVD DISC IN MODE: DVD STOP
2. UNLESS OTHERWISE SPECIFIED: ALL RESISTORS ARE 1/10W 45K METAL GLAZE RESISTOR OR 0.5K METAL GLAZE RESISTOR. ALL CAPACITORS ARE 50V 5% CERAMIC CAPACITOR. ALL RESISTANCE VALUES ARE IN OHM(D). ALL CAPACITANCE VALUES ARE IN #F16#PF. ALL CAPACITORS ARE SHOWN IN THE FORM OF CAPACITANCE(#F1)/RATED VOLTAGE (V). ALL INDUCTANCE VALUES ARE IN #H#RH#. 3. NI STANDS FOR NOT INSERTED PARTS. 4. DIGITAL TRANSISTOR



DVD servo and DVD system control section (2/2) / DVD tray loading control section

LVA10452-211B(2/2)

(SHEET 7)

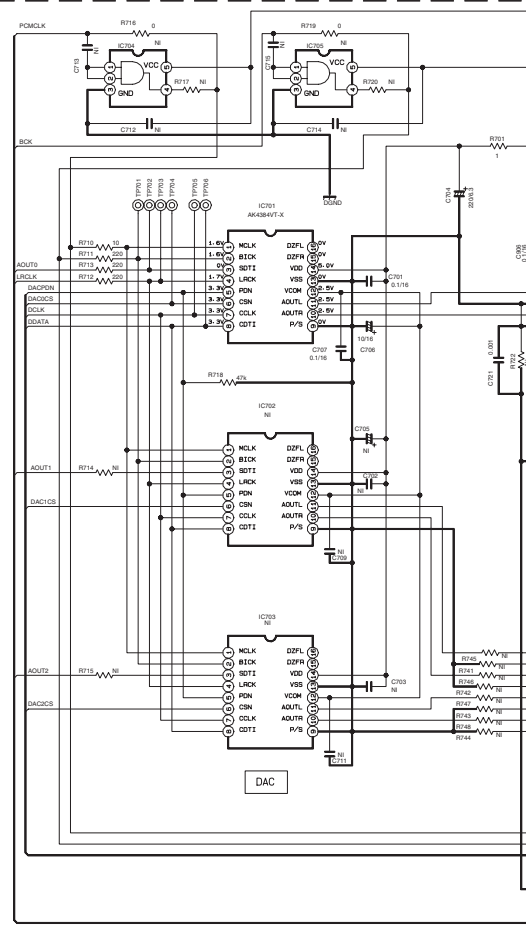
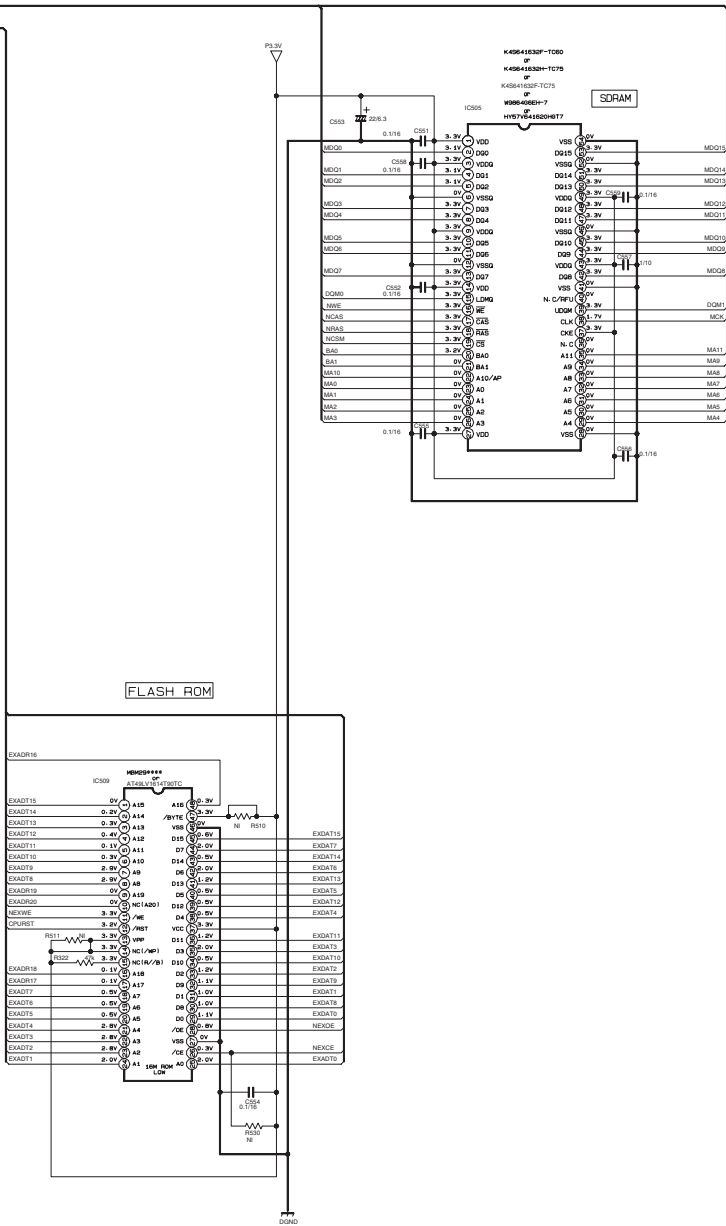

(SHEET 7)

NOTES

- VOLTAGES ARE DC-MEASURED WITH A DIGITAL VOLT METER WITHOUT INPUT CONDITION DVD DISC IN. MODE = DVD STOP
- UNLESS OTHERWISE SPECIFIED, ALL RESISTORS ARE 1/10W ±5% METAL GLAZE RESISTOR, OR 0.5X META ALL CAPACITORS ARE 50V OR 25V CERAMIC CAPACITOR. ALL RESISTANCE VALUES ARE IN Ω(M), ALL CAPACITANCE VALUES ARE IN pF(pF).
- ALL E. CAPACITORS ARE SHOWN IN THE FORM OF CAPACITANCE(pF)/RAT ALL INDUCTANCE VALUES ARE IN μH(mH).
- NI STANDS FOR NOT INSERTED PARTS.
- DIGITAL TRANSISTOR



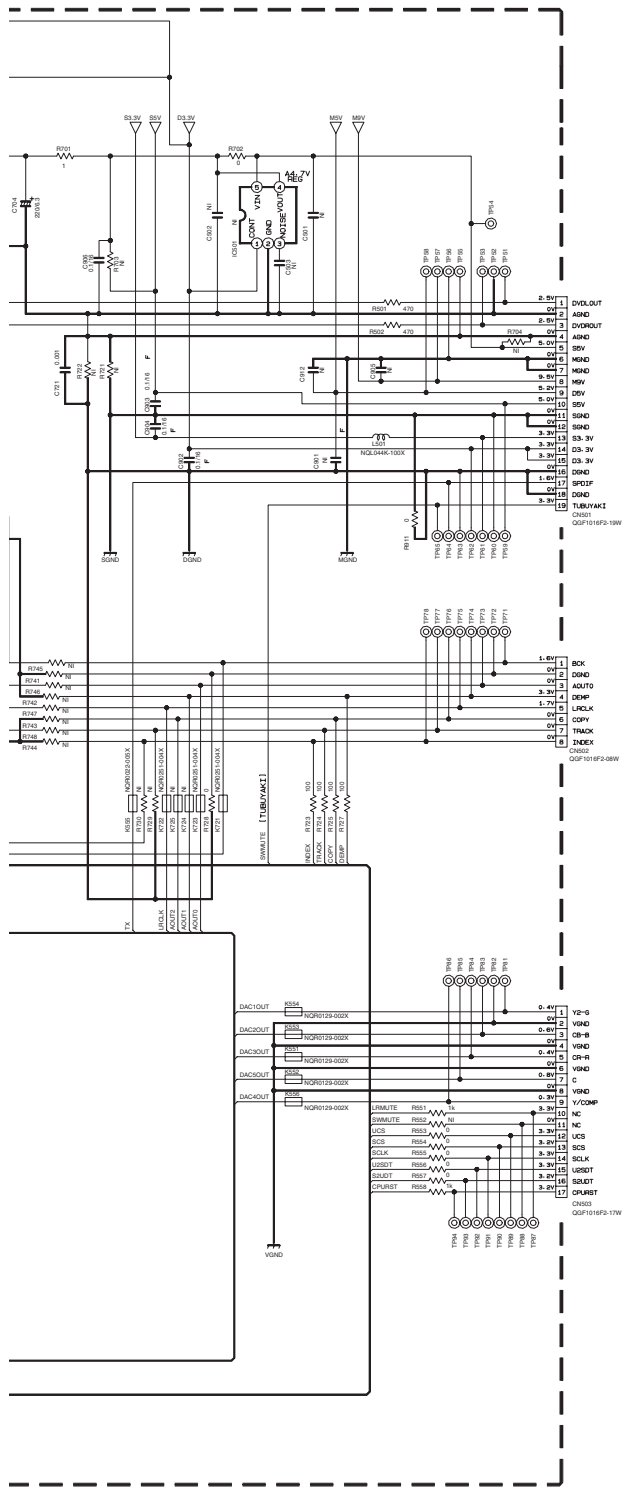

FROM CN202 OF GVA10059-A3
(SHEET 1)

TO CN703 OF GVA10059-A4
(SHEET 6)

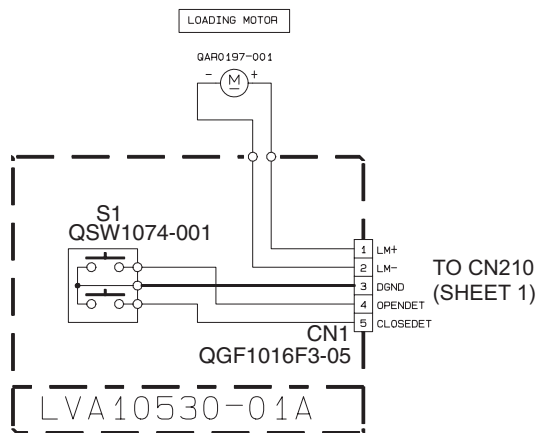

TER WITHOUT INPUT SIGNAL.
OR, OR 0.5X METAL GLAZE RESISTOR.
CAPITANCE(μF)/RATED VOLTAGE (V).



Printed circuit boards

■ Main board (1/2)

Lead free solder used in the board (material : Sn-Ag-Cu, melting point : 219 Centigrade)

(Micom board)

Forward side

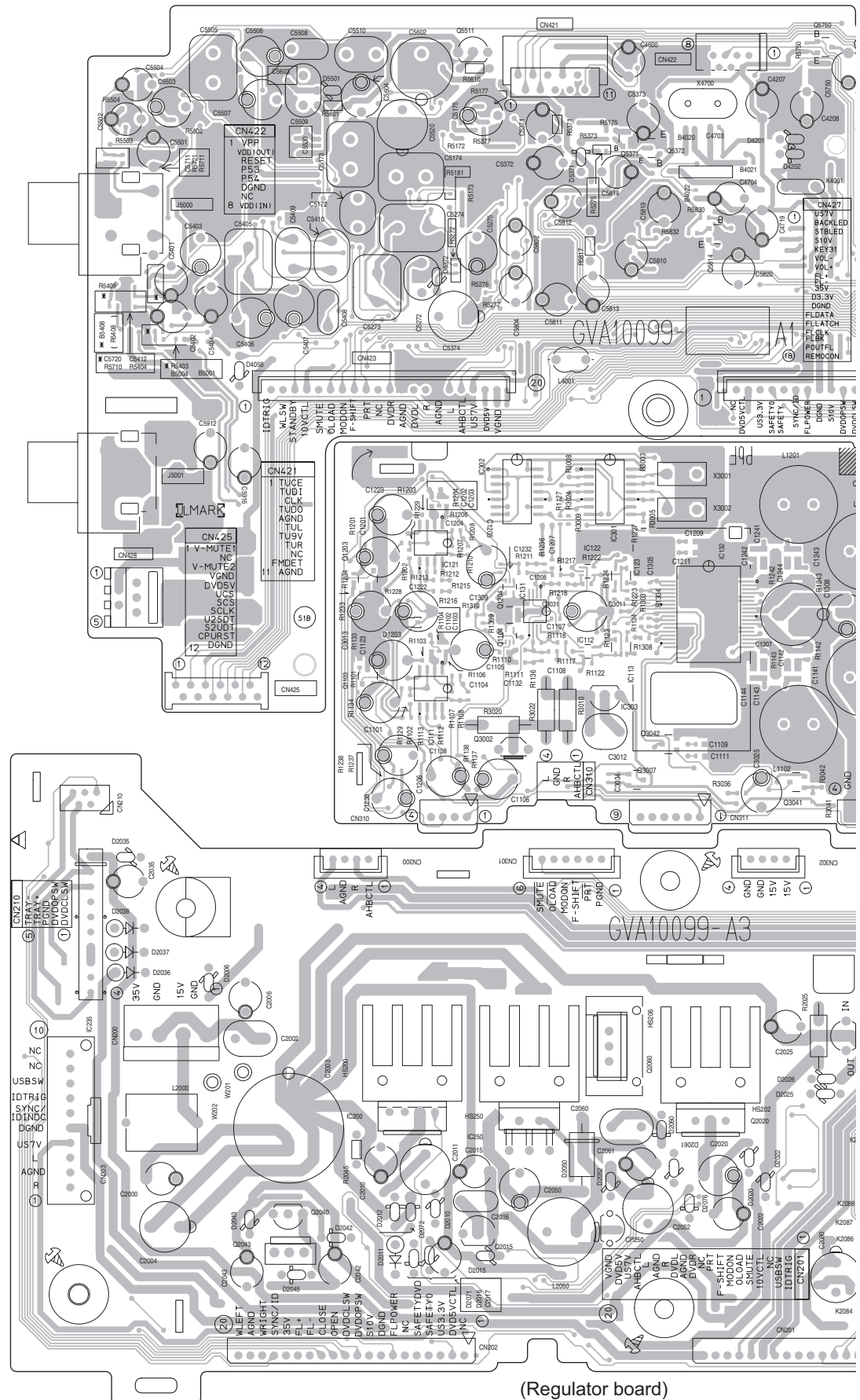

(Regulator board)

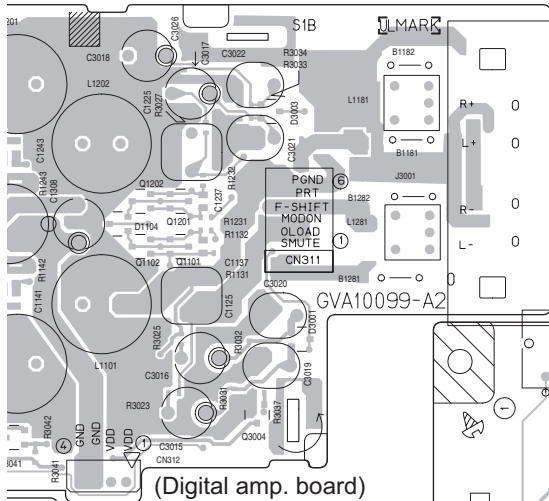
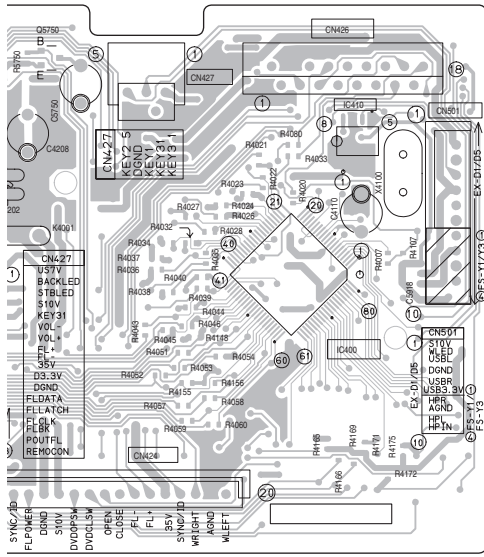

(Digital amp. board)

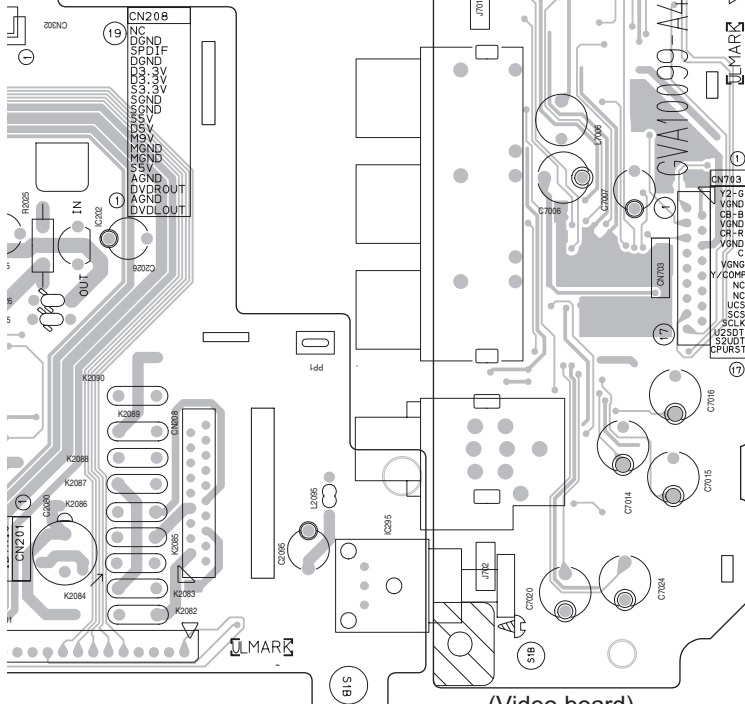

(Video board)

■ Main board (2/2)

Lead free solder used in the board (material : Sn-Ag-Cu, melting point : 219 Centigrade)

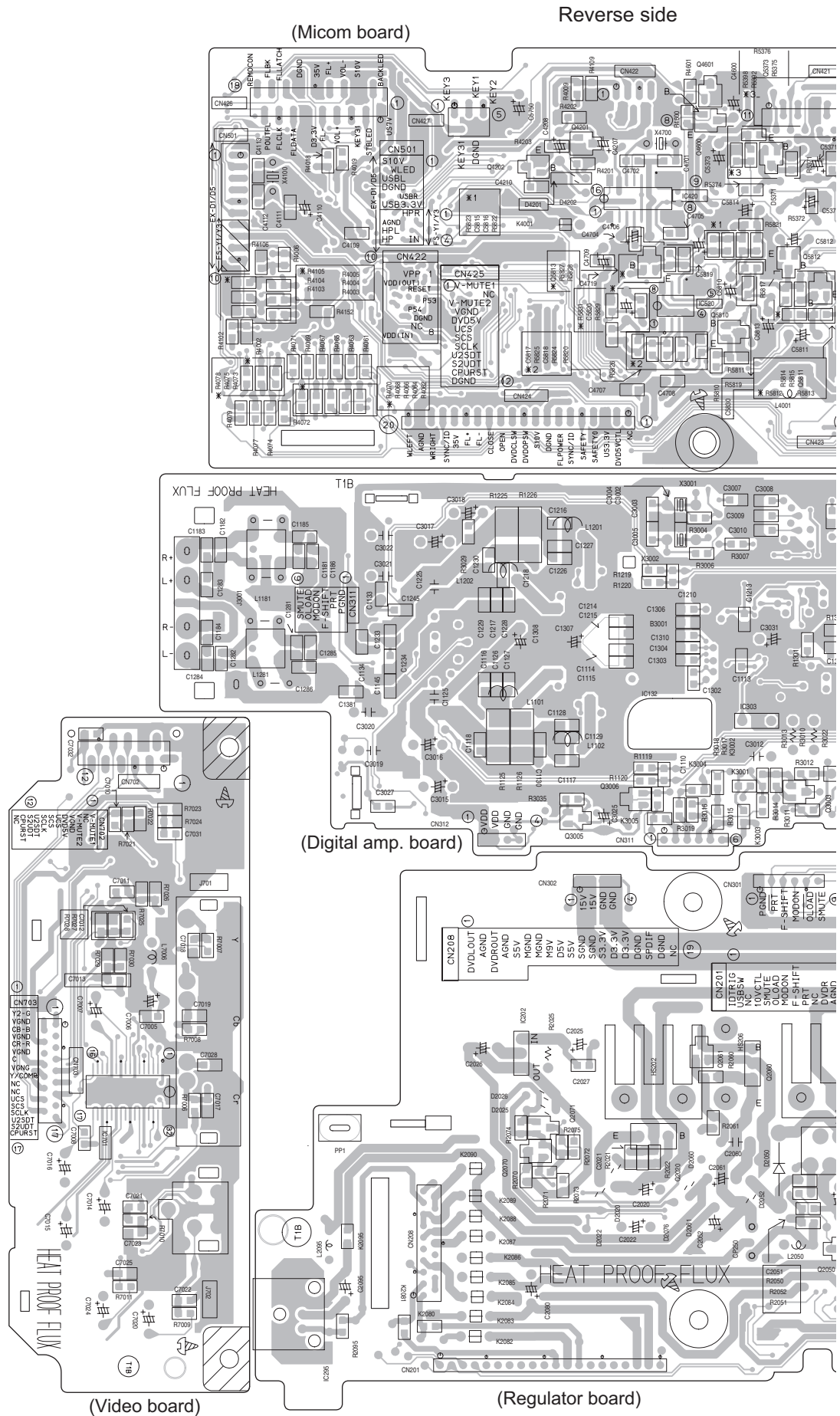

DVD module board

Lead free solder used in the board (material : Sn-Ag-Cu, melting point : 219 Centigrade)

Forward side

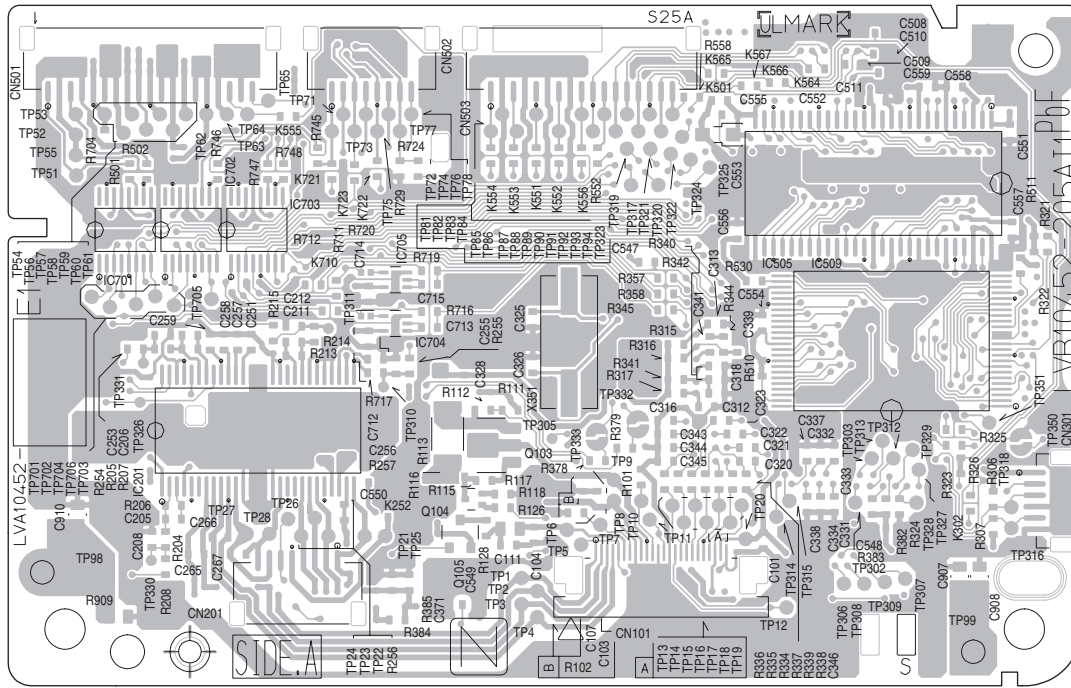

Reverse side

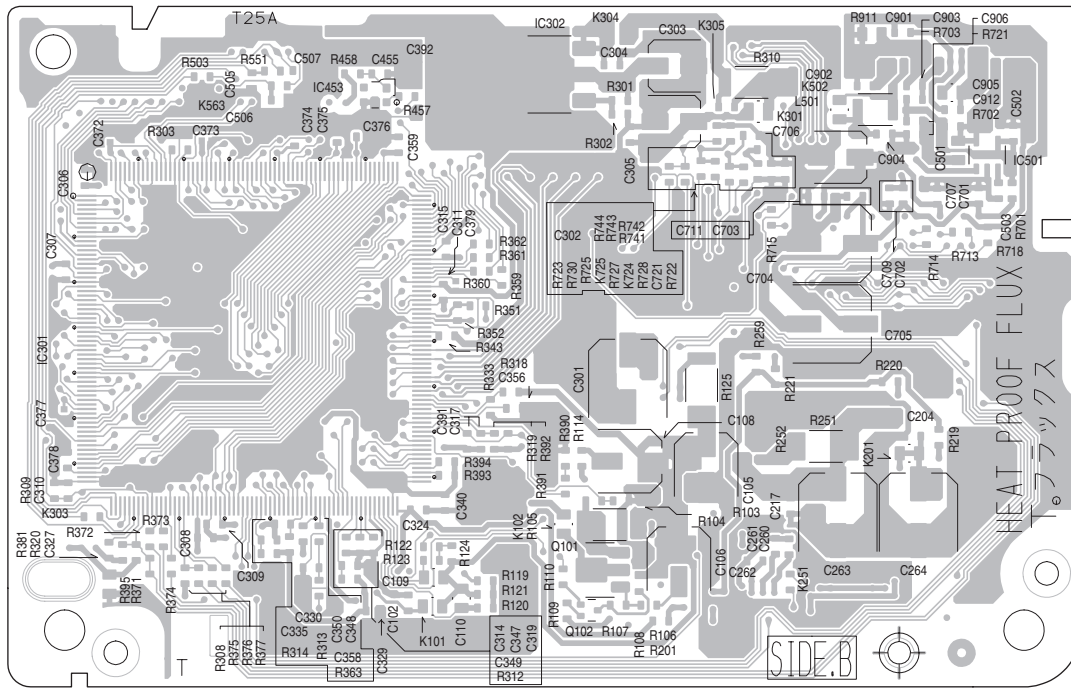

■ DVD loading switch board

Lead free solder used in the board (material : Sn-Ag-Cu, melting point : 219 Centigrade)

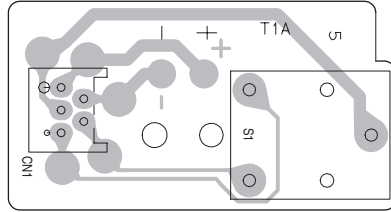

< MEMO >

JVC

Victor Company of Japan, Limited

AV & MULTIMEDIA COMPANY AUDIO/VIDEO SYSTEMS CATEGORY 10-1, 1chome, Ohwatari-machi, Maebashi-city, 371-8543, Japan

(No.MB376SCH)



Printed in Japan
VPT